

Magnetic Contactors and Magnetic Starters

# Exceed your expectations

Mitsubishi's Magnetic Contactors and Magnetic Starters, continuously pushing the boundaries.

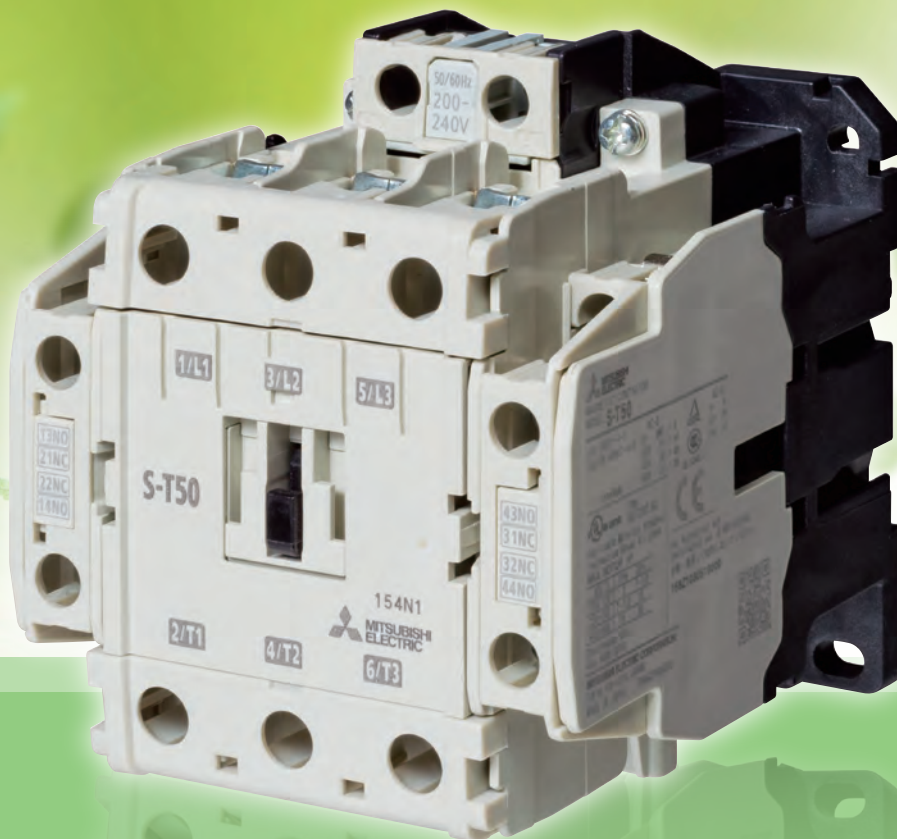

# MS-T Series

Mitsubishi Magnetic Contactors and Magnetic Starters

# Mitsubishi's Magnetic Contactors and Magnetic Starters continue to push the boundaries.

## MS-A Series

Double ratings of AC3 grade (Green) and AC4 grade (Red) were adopted allowing the unit to be downsized.



MS-A Series was released.

1933

1953

1960

1963

1968

1976

1982

1984

EC Series was released.

EK Series was released.

ES Series was released.

EM Series was released.

MS Series was released.



## EK Series

In cooperation with Westinghouse Electric Corporation, the clapper type EK Magnetic Contactor was developed.



## EM Series

Mitsubishi Electric introduced its own design of horizontal movement Magnetic Contactor with the EM series.



Mitsubishi Electric began making Magnetic Contactors and Magnetic Starters in 1933 with the first EC Series products. Since then consecutive new products and series have been highly appreciated by our customers. Our commitment to our customers remains to continuously develop our products to exceed their expectations.



**MS-T Series is released.**

The Motor Circuit Breaker was released.



**The 80th anniversary**

US-N Series was released.  
Sales of Magnetic Starters exceeded 100 million units.

US-H Series was released.

SD-Q Series was released.

MS-N Series was released.

US-K Series was released.

MS-K Series was released.



**MS-K Series**  
Lower power consumption was achieved through the use of AC operating, DC excited electromagnets.



**MS-N Series**  
The ground breaking "CAN terminal" proved to be an epoch making step in the design of Magnetic Contactors.



Meeting your needs	<b>4</b>
MS-T Series Introduction	<b>6</b>
— Features of MS-T Series	6
— List of Produced Models	11
Selection and Application	<b>14</b>
— About Handling	14
— Specification List Table	18
— Coordination with short-circuit protective devices	22
— Electrical Durability Curve	22
— Coil Ratings	22
— Contact Reliability	23
Application to Thermal Overload Relays	<b>24</b>
— Specification List	24
— Selection Table	26
— Precautions for Use	26
— Operating Characteristic of Thermal Overload Relays	27
Product Introduction	<b>30</b>
— Magnetic Starters	30
— Magnetic Contactors	32
— Thermal Overload Relays	33
— Contactor Relays	34
— Optional Units	36
Overseas Standard	<b>42</b>
Type Codes	<b>50</b>
Order Procedure	<b>52</b>
Outline Drawing	<b>54</b>
Warranty and Safety	<b>76</b>
Information of Our FA-related Products	<b>78</b>

Desire to  
down-size the  
switchboard



Desire to  
reduce the types  
and stock of  
switchboard  
parts



Desire to  
prevent  
accidents such  
as electric  
shock



Do these requirements sound familiar?



The new MS-T Series can help you solve these issues.



- S** Down-sizing
- S** Small
- S** Standardization
- S** Standardization
- S** Safety & Quality
- S** Safety & Quality
- S** Smart wiring
- S** Smart Wiring
- S** Global Standard
- S** Global Standard

# Down-sizing Small

## 10A frame model is over 16% smaller with a width of just 36mm!!

There is a saying that "every bit helps" and now with the industries smallest\* general purpose Magnetic Contactor in its class, customers are able to more easily down-size their boards than ever before.

For AC-operated 10A frame class general-purpose Magnetic Contactor (based on survey conducted by Mitsubishi dated September 2016)



S-T10 (actual size)

Reduction by 7mm!

Example: Status where 5 units are arranged

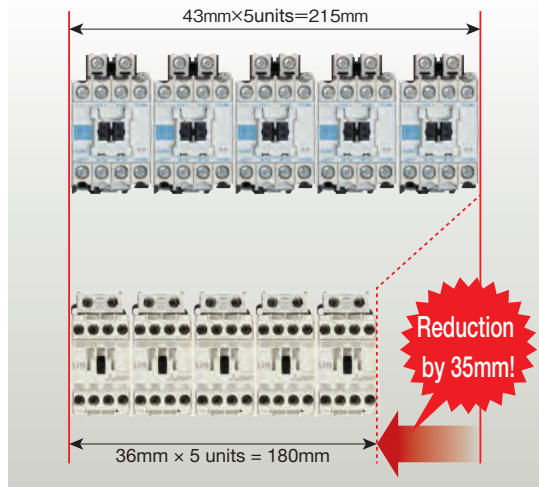

(For mounting details, please refer to "mounting on Page 14.)

Reduction by 35mm!

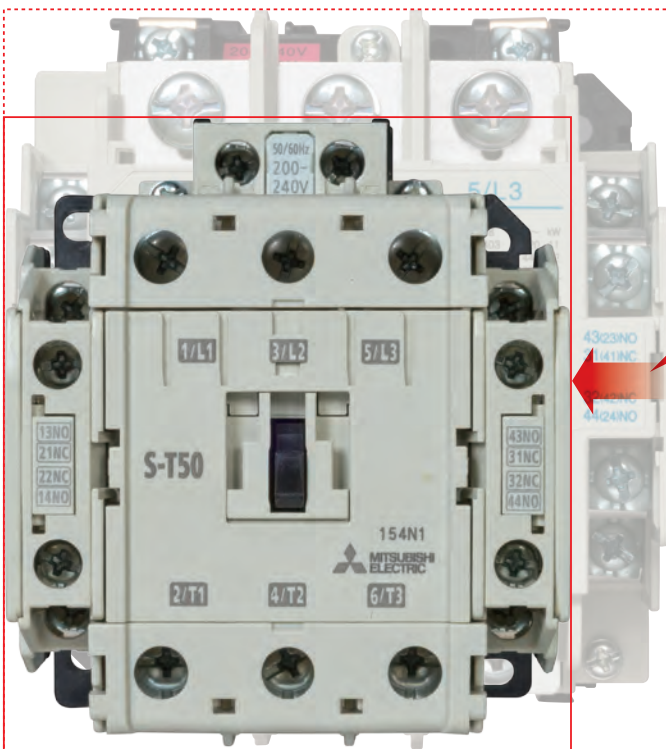

S-T50 (actual size)

Reduction by 13mm!

The optimized high-temperature gas discharge structure and arc runner shape streamline the outline dimensions!!

### Traditional MS-N Series

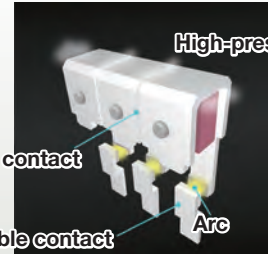

### New MS-T Series

Optimized high-temperature gas discharge structure  
High-pressure gas opening

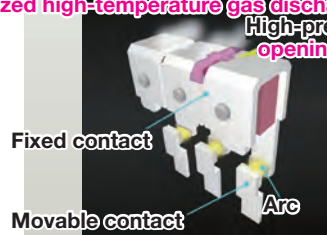

<AC operated type>

Frame size		11A	13A		20A	25A	32A
Traditional MS-N Series	Front view						-
		S-N10	S-N11 (Auxiliary 1-pole)	S-N12 (Auxiliary 2-pole)	S-N20	S-N25	
New slimline MS-T Series	Front view						
		S-T10	S-T12 (Auxiliary 2-pole)	S-T20	S-T25	S-T32	

Frame size		35A	50A		65A		80A	100A
Traditional MS-N Series	Front view							
		S-N35	S-N50	S-N50AE	S-N65	S-N65AE	S-N80	S-N95
New slimline MS-T Series	Front view							
		S-T35	S-T50	S-T65	S-T80	S-T100		

<DC operated type>

Front view		13A	18A	20A	32A
Traditional SD-N Series	Front view				-
		SD-N11	SD-N12	SD-N21	
New slimline SD-T Series	Front view				
		SD-T12	SD-T20	SD-T21	SD-T32

Front view		35A	50A	65A	80A	100A
Traditional SD-N Series	Front view					
		SD-N35	SD-N50	SD-N65	SD-N80	SD-N95
New slimline SD-T Series	Front view					
		SD-T35	SD-T50	SD-T65	SD-T80	SD-T100

MS-T Series Introduction

Selection and Application

Application to Thermal Overload Relays

Product Introduction

Overseas Standard

Type Codes

Order Procedure

Outline Drawing

Warranty and Safety

# Standardization Standardization

## New integrated terminal covers Target frame : 10A to 50A frame

The perennial issues of remembering to order the terminal covers, fitting them correctly or losing them in the process are challenges of the past. The integrated terminal cover system means they are always there, on the Magnetic Contactor or its Auxiliary contact, ready to be used.

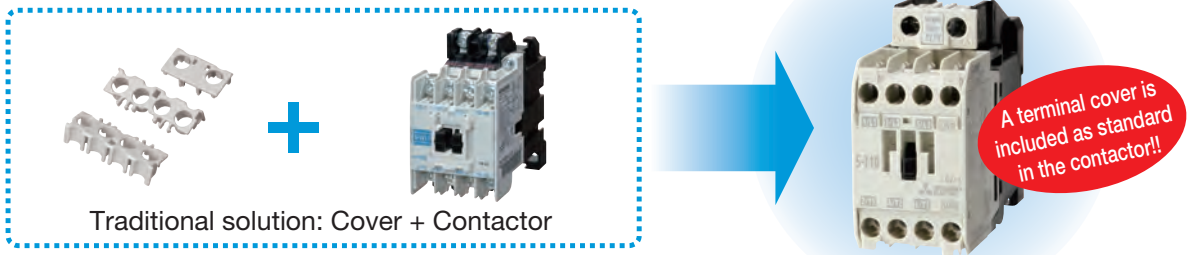

## Reduce your coil inventory by up to 50% Target frame : 10A to 35A frame

The 14 types of operation coil ratings available with the SN Series have been halved to 8 types with that increasing the applicable voltage range. Users can reduce their inventory, and by integrating the types of coils manufactured, a shorter delivery can be realized.

Coil designation	Rated voltage [V]	
	50Hz	60Hz
AC12V	12	12
AC24V	24	24
AC48V	48-50	48-50
AC100V	100	100-110
AC120V	110-120	115-120
AC127V	125-127	127
AC200V	200	200-220
AC220V	208-220	220
AC230V	220-240	230-240
AC260V	240-260	260-280
AC380V	346-380	380
AC400V	380-415	400-440
AC440V	415-440	460-480
AC500V	500	500-550



Coil designation	Rated voltage [V]
	50Hz/60Hz
AC12V	12
AC24V	24
AC48V	48-50
AC100V	100-127
AC200V	200-240
AC300V	260-300
AC400V	380-440
AC500V	460-550

\* The conventional eight types are available for the 50A and larger frames.

By integrating the electromagnetic field analysis and drive analysis, inconsistency in the electromagnetic attraction force is suppressed and rise of the coil temperature is reduced.

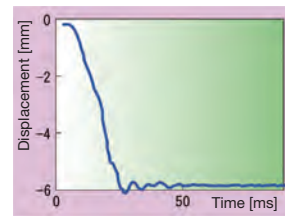
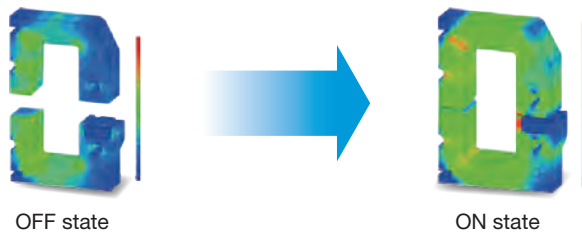

When AC150V 60Hz is applied on AC200V coil

## Capable of direct drive with transistor output of PLC, etc Target frame : 10A to 32A frame \*DC-operated models

The adopted high-efficiency polarized electromagnet greatly reduces the coil power consumption, and enables all models to be directly driven with a DC24V, 0.1A rating transistor output. (DC24V coil)

	Conventional Model	New Model	Lowering Rate
13A Frame (Coil:DC12/24V)	7W	2.2W	69%
20A Frame (Coil:DC12/24V)	9W	2.2W	76%
32A Frame (Coil:DC12/24V)	-	2.2W	-

\*DC48V to 220V:3.3W

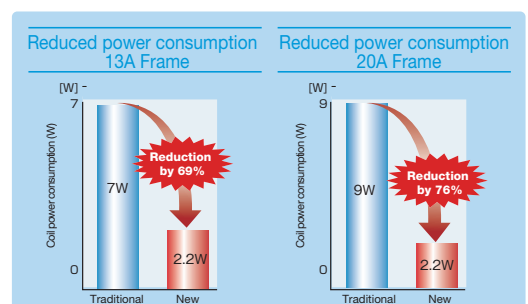



Safety &amp; Quality

# Safety & Quality

## Terminal cover with finger protection function

Target frame : 10A to 50A frames

In addition to the Magnetic Contactor, a terminal cover has been provided as a standard for the thermal, magnetic relay and auxiliary contact unit options. This realizes a finger protection function that complies with the DIN and VDE Standards, prevents electric shocks, and increases safety during maintenance and inspections.

[Finger Protection]

In the provisions regarding worker safety and accident protection during use of low-voltage switchgear and controlgear assemblies set forth with DIN EN 50274/VDE 0660 Teil 514, the range for providing protection against contact of live sections is divided into "Finger Safe (preventing finger contact)" and "Back of hand safe (protecting back of hand contact), and standards are provided. The MS-T Series terminal cover satisfies the requirements of these provisions.



## A light touch

Target frame : All S-T Series

The MS-T Series' auxiliary contacts can operate with load as light as 20V 3mA making it suitable for direct control/operation from a PLC output.



Smart wiring

# Smart Wiring

## Smart design means Smart wiring

Target frame : 10A to 50A frames

The integrated terminal covers have an additional benefit in that they act as a guide to improve wiring efficiency but also retain the terminal screw in place: no mislaying the screw, no dropping it or having trouble reinserting it in to the terminal block just fast efficient wiring. Fast wiring terminals (model name with suffix "BC" ) are also available to further improve wiring efficiency, workability and hence productivity.



① Screw holder lifts up the screw.



② Insert a ring crimp lug



③ Tighten the screw

Easy wiring!



# List of Produced Models

## Magnetic Starters/Magnetic Contactors (NonReversing)

Frame		T10	T12	T20	T21	T25	T32	T35	T50	T65	T80	T100	N125	N150	N180	N220	N300	N400	N600	N800				
Category AC-3	220V	2.5 [2.2]	3.5 [2.7]	4.5 [3.7]	5.5 [4]	7.5 [5.5]	7.5 [7.5]	11 [7.5]	15 [11]	18.5 [15]	22 [19]	30 [22]	30	37	45	55	75	110	160	200				
	Rated capacity [kW]	440V	4 [2.7]	5.5 [4]	7.5 [7.5]	11 [7.5]	15 [11]	15 [15]	18.5 [15]	22 [22]	30 [30]	45 [37]	55 [45]	60	75	90	110	150	200	300	400			
Auxiliary contact		standard	1a	1a1b	1a1b	← 2a2b →		← 2a2b →																
Model Name		special	1b	2a	2a	—	—	—	—	—	—	—	—	—	—	—	—	—	—	—	—			
Magnetic Starters	Enclosed	Standard specifications	MS-□	○	○	—	○	—	○	○	○	○	○	○	○	○	○	○	○	—	—			
		With push button	MS-□PM	○	○	—	○	—	○	○	○	○	○	○	—	—	—	—	—	—	—	—		
		3-element (2E) thermal	MS-□KP	○	○	—	○	—	○	○	○	○	○	○	○	○	○	○	○	○	○	—	—	
		Open time quick motion type	MS-□QM	—	—	—	—	—	—	—	—	○	○	○	○	○	○	○	○	○	○	—	—	
	Open type	Standard specifications	MSO-□	○	○	○	○	○	—	○	○	○	○	○	○	○	○	○	○	○	○	—	—	
			MSOD-□	—	○	○	○	—	—	○	○	○	○	○	○	○	—	○	○	○	○	—	—	
		3-element (2E) thermal	MSO-□KP	○	○	○	○	○	—	○	○	○	○	○	○	○	○	○	○	○	○	○	—	—
			MSOD-□KP	—	○	○	○	—	—	○	○	○	○	○	○	○	—	○	○	○	○	○	—	—
		With saturable reactor	MSO-□SR	○	○	○	○	○	—	○	○	○	○	○	○	○	○	○	○	○	○	○	—	—
			MSOD-□SR	—	○	○	○	—	—	○	○	○	○	○	○	○	—	○	○	○	○	○	—	—
		3-element (2E) thermal With saturable reactor	MSO-□KPSR	—	—	—	○	○	—	○	○	○	○	○	○	○	○	○	○	○	○	○	—	—
			MSOD-□KPSR	—	—	—	○	—	—	○	○	○	○	○	○	○	—	○	○	○	○	○	—	—
		2-element Quick-acting characteristics thermal	MSO-□FS	—	—	—	○	○	—	○	○	○	○	○	—	—	—	—	—	—	—	—	—	
			MSOD-□FS	—	—	—	○	—	—	○	○	○	○	○	—	—	—	—	—	—	—	—	—	
		3-element (2E) Quick-acting characteristics thermal	MSO-□FSKP	○	○	○	○	○	—	○	○	○	○	○	—	—	—	—	—	—	—	—	—	
			MSOD-□FSKP	—	○	○	○	—	—	○	○	○	○	○	—	—	—	—	—	—	—	—	—	
		3-element (2E) Quick-acting characteristics thermal	MSO-□KF	—	—	—	—	—	—	—	—	—	—	—	—	—	—	—	—	—	—	—	—	
			MSOD-□KF	—	—	—	—	—	—	—	—	—	—	—	—	—	—	—	—	—	—	—	—	
		Open time quick motion type	MSO-□QM	—	—	—	—	—	—	—	—	○	○	○	○	○	○	○	○	○	○	○	—	—
			MSOD-□QM	—	—	—	—	—	—	—	—	—	—	—	—	—	—	—	—	—	—	—	—	
Surge absorber mounted type	MSO-□SA	○	○	○	○	○	—	○	○	—	—	—	—	—	—	—	—	—	—	—	—			
	MSOD-□SA	—	○	○	○	—	—	○	○	—	—	—	—	—	—	—	—	—	—	—	—			
Wiring streamlining terminal	MSO-□BC	○	○	○	○	○	—	○	○	—	—	—	—	—	—	—	—	—	—	—	—			
	MSOD-□BC	—	○	○	○	—	—	○	○	—	—	—	—	—	—	—	—	—	—	—	—			
Anticorrosion treatment	MSO-□YS	○	○	○	○	○	—	○	○	○	○	○	○	○	○	○	○	○	○	○	—	—		
	MSOD-□YS	—	○	○	○	—	—	○	○	○	○	○	○	○	—	○	○	○	○	○	—	—		
Delay open type	MSO-□DL	—	○	—	○	—	—	○	○	○	○	○	—	○	—	○	○	○	○	○	—	—		
	MSOD-□DL	—	—	—	—	—	—	—	—	—	—	—	—	—	—	—	—	—	—	—	—			
Mechanically latched type	MSOL-□	—	—	—	○	—	—	○	○	○	○	○	○	○	—	○	○	○	○	○	—	—		
	MSOLD-□	—	—	—	○	—	—	○	○	○	○	○	○	○	—	○	○	○	○	○	—	—		
With terminal cover	MSO-□CW	—	—	—	—	—	—	—	—	○	○	—	—	—	—	—	—	—	—	—	—			
	MSOD-□CW	—	—	—	—	—	—	—	—	—	—	—	—	—	—	—	—	—	—	—	—			
Magnetic Contactors	Standard specifications	S-□	○	○	○	○	○	○	○	○	○	○	○	○	○	○	○	○	○	○	○	○		
		SD-□	—	○	○	○	—	—	○	○	○	○	○	○	○	—	○	○	○	○	○	○		
	Surge absorber mounted type	S-□SA(Notes3)	○	○	○	○	○	○	○	○	—	—	—	—	—	—	—	—	—	—	—	—		
		SD-□SA	—	○	○	○	—	—	○	○	—	—	—	—	—	—	—	—	—	—	—	—		
	Anticorrosion treatment	S-□YS	—	—	—	—	—	—	○	○	○	○	○	○	○	○	○	○	○	○	○	○		
		SD-□YS	—	—	—	—	—	—	—	—	—	—	—	—	—	—	—	—	—	—	—	—		
	Open time quick motion type	S-□QM	—	—	—	—	—	—	—	—	—	○	○	○	○	○	○	○	○	○	○	—		
		SD-□QM	—	—	—	—	—	—	—	—	—	—	—	—	—	—	—	—	—	—	—	—		
	Wiring streamlining terminal	S-□BC	○	○	○	○	○	○	○	○	—	—	—	—	—	—	—	—	—	—	—	—		
		SD-□BC	—	○	○	○	—	—	○	○	—	—	—	—	—	—	—	—	—	—	—	—		
With terminal cover	S-□CW	—	—	—	—	—	—	—	—	○	○	—	—	—	—	—	—	—	—	—	—			
	SD-□CW	—	—	—	—	—	—	—	—	—	—	—	—	—	—	—	—	—	—	—	—			
Delay open type	S-□DL	—	○	—	○	—	—	*	*	*	*	*	—	○	—	○	○	○	○	○	—			
	SD-□DL	—	—	—	—	—	—	—	—	—	—	—	—	—	—	—	—	—	—	—	—			
Mechanically latched type	SL-□	—	—	—	○	—	—	○	○	○	○	○	○	○	—	○	○	○	○	○	○			
	SLD-□	—	—	—	○	—	—	○	○	○	○	○	○	○	—	○	○	○	○	○	○			
Class 2 heat resistance	S-□FN	—	○	—	○	—	—	*	*	—	*	*	—	○	—	—	—	—	○	—	—			
	SL-T□FN	—	—	—	○	—	—	—	*	—	*	*	—	○	—	—	—	—	○	—	—			
Class 2 heat resistance Mechanically latched type	S-□FN	—	—	—	○	—	—	—	*	—	*	*	—	○	—	—	—	—	○	—	—			
	SLD-T□FN	—	—	—	○	—	—	—	*	—	*	*	—	○	—	—	—	—	○	—	—			

Note 1: The figure in the square brackets indicates the rated current shown on the rating plate of the product at which the category AC-3 opening/closing durability is 2,000,000 times (1,000,000 times for the T20 380V). Refer to the electric durability curve for the life performance.

## List of Produced Models

### Magnetic Starters/Magnetic Contactors (Reversing)

Frame		2X T10	2X T12	2X T20	2X T21	2X T25	2X T32	2X T35	2X T50	2X T65	2X T80	2X T100	2X N125	2X N150	2X N180	2X N220	2X N300	2X N400	2X N600	2X N800				
Category AC-3 Rated capacity [kW]	220V	2.5 [2.2]	3.5 [2.7]	4.5 [3.7]	5.5 [4]	7.5 [5.5]	7.5 [7.5]	11 [11]	15 [15]	18.5 [15]	22 [19]	30 [22]	30	37	45	55	75	110	160	200				
	440V	4 [2.7]	5.5 [4]	7.5 [7.5]	11 [7.5]	15 [11]	15 [15]	18.5 [15]	22 [22]	30 [30]	45 [37]	55 [45]	60	75	90	110	150	200	300	400				
Auxiliary contact (Notes 4 to 6)	Standard	(1a×2)+2b		(1a1b×2)+2b		2a2b×2						3a3b×2						4a4b×2						
	Special	(1b×2)+2b		(2a×2)+2b		-		-		-		-		-		-		-		-				
Model Name																								
Magnetic Starters	Enclosed	Standard specifications	MS-□	-	-	-	○	-	-	○	○	○	○	○	○	○	○	○	○	○	-	-		
		3-element (2E) thermal	MS-□KP	-	-	-	○	-	-	○	○	○	○	○	○	○	○	○	○	○	○	-	-	
	Open type	Standard specifications	MSO-□	○	○	○	○	-	-	○	○	○	○	○	○	○	○	○	○	○	○	-	-	
		MSOD-□	-	○	○	○	-	-	-	○	○	○	○	○	○	-	○	○	○	○	○	-	-	
	3-element (2E) thermal	MSO-□KP	○	○	○	○	○	-	-	○	○	○	○	○	○	○	○	○	○	○	○	-	-	
		MSOD-□KP	-	○	○	○	-	-	-	○	○	○	○	○	○	-	○	○	○	○	○	-	-	
	With saturable reactor	MSO-□SR	○	○	○	○	○	-	-	○	○	○	○	○	○	○	○	○	○	○	○	-	-	
		MSOD-□SR	-	○	○	○	-	-	-	○	○	○	○	○	○	-	○	○	○	○	○	-	-	
	3-element (2E) thermal With saturable reactor	MSO-□KPSR	-	-	-	○	○	-	-	○	○	○	○	○	○	○	○	○	○	○	○	-	-	
		MSOD-□KPSR	-	-	-	○	-	-	-	○	○	○	○	○	○	-	○	○	○	○	○	-	-	
	2-element Quick-acting characteristics thermal	MSO-□FS	-	-	-	○	○	-	-	○	○	○	○	○	-	-	-	-	-	-	-	-	-	
		MSOD-□FS	-	-	-	○	-	-	-	○	○	○	○	○	-	-	-	-	-	-	-	-	-	
	3-element (2E) Quick-acting characteristics thermal	MSO-□FSKP	○	○	○	○	○	-	-	○	○	○	○	○	-	-	-	-	-	-	-	-	-	
		MSOD-□FSKP	-	○	○	○	-	-	-	○	○	○	○	○	-	-	-	-	-	-	-	-	-	
	3-element (2E) Quick-acting characteristics thermal	MSO-□KF	-	-	-	-	-	-	-	-	-	-	-	-	-	-	-	-	-	-	-	-	-	
		MSOD-□KF	-	-	-	-	-	-	-	-	-	-	-	-	-	-	-	-	-	-	-	-	-	
	Surge absorber mounted type	MSO-□SA	○	○	○	○	○	-	-	○	○	-	-	-	-	-	-	-	-	-	-	-	-	
		MSOD-□SA	-	○	○	○	-	-	-	○	○	-	-	-	-	-	-	-	-	-	-	-	-	
	Wiring streamlining terminal	MSO-□BC	○	○	○	○	○	-	-	○	○	-	-	-	-	-	-	-	-	-	-	-	-	
		MSOD-□BC	-	○	○	○	-	-	-	○	○	-	-	-	-	-	-	-	-	-	-	-	-	
With terminal cover	MSO-□CW	-	-	-	-	-	-	-	-	○	○	-	-	-	-	-	-	-	-	-	-	-		
	MSOD-□CW	-	-	-	-	-	-	-	-	-	-	-	-	-	-	-	-	-	-	-	-	-		
Anticorrosion treatment	MSO-□YS	○	○	○	○	○	-	-	○	○	○	○	○	○	○	○	○	○	○	○	-	-		
	MSOD-□YS	-	○	○	○	-	-	-	○	○	○	○	○	○	-	○	○	○	○	○	-	-		
Mechanically latched type	MSOL-□	-	-	-	○	-	-	○	○	○	○	○	○	○	-	○	○	○	○	○	-	-		
	MSOLD-□	-	-	-	○	-	-	-	○	○	○	○	○	○	-	○	○	○	○	○	-	-		
Magnetic Contactors	Open type	Standard specifications	S-□	○	○	○	○	○	○	○	○	○	○	○	○	○	○	○	○	○	○	○	○	
		SD-□	-	○	○	○	-	○	○	○	○	○	○	○	○	-	○	○	○	○	○	○	○	
		Surge absorber mounted type	S-□SA <sup>(Note3)</sup>	○	○	○	○	○	○	○	-	-	-	-	-	-	-	-	-	-	-	-	-	
		SD-□SA	-	○	○	○	-	○	○	○	-	-	-	-	-	-	-	-	-	-	-	-	-	
		Anticorrosion treatment	S-□YS	-	-	-	-	-	-	○	○	○	○	○	○	○	○	○	○	○	○	○	○	○
		Wiring streamlining terminal	S-□BC	○	○	○	○	○	○	○	-	-	-	-	-	-	-	-	-	-	-	-	-	-
			SD-□BC	-	○	○	○	-	○	○	○	-	-	-	-	-	-	-	-	-	-	-	-	-
		With terminal cover	S-□CW	-	-	-	-	-	-	-	-	○	○	-	-	-	-	-	-	-	-	-	-	-
			SD-□CW	-	-	-	-	-	-	-	-	-	-	-	-	-	-	-	-	-	-	-	-	-
		Mechanically latched type	SL-□	-	-	-	○	-	-	○	○	○	○	○	○	○	-	○	○	○	○	○	○	○
			SLD-□	-	-	-	○	-	-	-	○	○	○	○	○	○	-	○	○	○	○	○	○	○
		Class 2 heat resistance	S-□FN	-	○	-	○	-	-	○	○	-	○	○	-	○	-	-	-	-	○	-	-	-
			SD-□FN	-	○	-	○	-	-	-	○	○	-	○	○	-	-	-	-	-	○	-	-	-
		With reversible conductor (both power supply and load side)	S-□SD	○	○	○	○	○	○	○	○	○	○	○	○	○	○	○	○	○	○	○	○	○
SD-□SD	-		○	○	○	-	○	○	○	○	○	○	○	○	-	○	○	○	○	○	○	○		
3-pole common on power supply side with crossover conductor	S-□SG	○	○	○	○	○	○	○	○	○	○	○	○	○	○	○	○	○	○	○	○	○		
	SD-□SG	-	○	○	○	-	○	○	○	○	○	○	○	○	-	○	○	○	○	○	○	○		
3-pole common on load side with crossover conductor	S-□SX	○	○	○	○	○	○	○	○	○	○	○	○	○	○	○	○	○	○	○	○	○		
	SD-□SX	-	○	○	○	-	○	○	○	○	○	○	○	○	-	○	○	○	○	○	○	○		
3-pole reverse-phase switch on load side with crossover conductor	S-□SF	○	○	○	○	○	○	○	○	○	○	○	○	○	○	○	○	○	○	○	○	○		
	SD-□SF	-	○	○	○	-	○	○	○	○	○	○	○	○	-	○	○	○	○	○	○	○		

Note 1: - indicates out of manufacturing range, and \* indicates to be released soon.  
 Note 2: The value given in brackets for the Class AC-3 rated capacity applies to the enclosed Magnetic Starter.  
 Note 3: The T65 to N800 type AC operation coils are a surge absorber-installed type so the coil does not generate an open/close surge. Therefore, the surge absorber for coils is not required.  
 Note 4: The +2b for the T10 to T20 auxiliary contact arrangements in the Reversing type represents the b contact built into the UT-ML11 interlock unit. This does not need to be specified when ordering.  
 Note 5: For the auxiliary contact arrangement in the reversing type, the auxiliary contact arrangement combination for two Magnetic Contactors is indicated as ×2. When using the standard contact

arrangement, there is no need to make a special designation, but when using the special arrangement, designate the contact arrangement for two units.  
 <Designation example> In case of 1b × 2 + 2b: 2B  
 Note 6: The auxiliary contact arrangement for the mechanically latched type differs from the delay open type.

## ● Thermal Overload Relays

Frame		T18	T25	T50	T65	T100	N120	N120TA	N220	N400	N600
Heater designation (Standard specifications)		0.12 to 15	0.24 to 22	24 to 50	12 to 65	54 to 100	42 to 82	105 to 125	82 to 180	105 to 330	250 to 660
Thermal Overload Relays	Standard specifications TH-□	○	○	○	○	○	○	○	○	○	○
	With saturable reactor TH-□SR	○	○	○	○	○	○	○	○	○	○
	2-element Quick-acting characteristics thermal TH-□FS	—	○	○	○	○	—	—	—	—	—
	3-element (2E) thermal TH-□KP	○	○	○	○	○	○	○	○	○	○
	3-element (2E) thermal With saturable reactor TH-□KPSR	—	○	○	○	○	○	○	○	○	○
	3-element (2E) Quick-acting characteristics thermal TH-□FSKP	○	○	○	○	○	—	—	—	—	—
	TH-□KF	—	—	—	—	—	—	—	—	—	—
	With terminal cover TH-□CW	—	—	—	○	—	—	—	—	—	—
	Wiring streamlining terminal TH-□BC	○	○	○	—	—	—	—	—	—	—
	Anticorrosion treatment TH-□YS	○	○	○	○	○	○	○	○	○	○

Note 1: — indicates out of manufacturing range.

## ● Contactor Relays

Frame		T5	T9
Number of contact		5	9
Contact arrangement		5a	9a
		4a1b	7a2b
		3a2b	5a4b
Standard	SR-□	○	○
DC operated type	SRD-□	○	○
Mechanically latched type	SRL-□	○	—
	SRLD-□	○	—
With large rated auxiliary contacts	SR-□JH	○	○
	SRD-□JH	○	○
With overlap contact	SR-□LC	○	○
	SRD-□LC	○	○
Delay open type	SR-□DL	○	○
With fast wiring terminal	SR-□BC	○	○
	SRD-□BC	○	○
With surge absorber	SR-□SA	○	○
	SRD-□SA	○	○

Note 1: — indicates out of manufacturing range.

Note 2: Refer to the individual rating table for the contact rating when using a type with large capacity contact or type with overlap contact. The value given in brackets is the value for switching the load with two poles installed in a series.

Note 3: When using the mechanically latched type (SRL-□, SRLD-□), one each can be mounted on the opening coil and closing coil.

Note 4: Only the side-on auxiliary contact unit UT-AX11 can be mounted on the mechanically latched type SRL-T5 or SRLD-T5. Only UN-AX11 can be mounted on SRL-N4 or SRLD-N4.

Note 5: Both the surge absorber unit and DC/AC interface unit cannot be additionally mounted onto the Contactor Relay's coil terminal.

Note 6: A live section protection cover is provided as a standard.

Note 7: The minimum applicable load level for the contacts at the SR(D)-T9 head-on section (four terminals on upper level) is the same as UT-AX2/4.

## About Handling

### Note

## Precautions for Use

- ⚠ Be sure to periodically check the Magnetic Starters and apply danger prevention measures on the sequence of important circuits. (The Magnetic Starters contacts may suffer from defective continuity, welding, and burning. )
- ⚠ When performing installation, wiring, and maintenance & inspection, be sure to disconnect the Magnetic Starters from the power supply. It may cause electric shock. In addition, the malfunction attributable to vibration, impact, and false wiring may exert serious results (machine malfunction, short-circuiting of power supply, etc.) on the Magnetic Contactors.

## Performance

The performance described in this catalog is based on the result of a test conducted under the conditions specified in the Standard (IEC60947-4-1 "Low-voltage switchgear and controller" etc.). If actual use condition is different from this test condition, the user must evaluate the condition (by using an actual device).

## Use condition

Although the device can operate without any problem when under the conditions described in this chapter, be careful about the following matters.

### (1) Ambient temperature

Even when the device is used in accordance with normal usage, deterioration of the insulation will progress.

In particular, as the ambient temperature increases, the insulation life is shortened. In general, it is said that every time the ambient temperature increases by 6 to 10°C, the insulation life decreases by half (Arrhenius law). In a case where the ambient temperature is high and voltage exceeding the rated voltage is continuously applied to coil, the coil temperature increases and life may be shortened dramatically.

### (2) Vibration/Impact

Although vibration of 19.6m/s<sup>2</sup> and impact of 49m/s<sup>2</sup> do not cause contact malfunction, even when the vibration and impact are below these values but are applied continuously, fatigue failure may cause some trouble.

In particular, please note that the resonance of an installed board may exert a large vibration on the product.

## Usage environment

- (1) Ambient temperature : -10°C to 40°C  
(Applied to the outside of the control board) Average daily atmospheric temperature: 35°C (Max.), Average yearly atmospheric temperature: 25°C (Max.)
- (2) Maximum temperature of the inside of the control board : 55°C However, the ambient temperature of boxed MS type is 40°C (Average yearly temperature of the inside of the control board is 40°C or less.)  
Please note that the operating characteristics of the Magnetic Contactors and Thermal Overload Relays may vary with the ambient temperature.
- (3) Relative humidity : 45% to 85% RH However, dew condensation and freezing should be avoided.
- (4) Height above sea level : 2000 m or less
- (5) Vibration : 10 to 55 Hz, 19.6 m/s<sup>2</sup> or less
- (6) Impact : 49 m/s<sup>2</sup> or less
- (7) Atmosphere : Inclusion of dust, smoke, corrosive gas, moisture, salt content and the like in the atmosphere should be avoided as much as possible.  
Please note that continuing to use the device in a closed condition for a long period may cause contact failure.  
Never use the device under an atmosphere that contains flammable gas.
- (8) Storage temperature/Relative humidity : -30°C to 65°C 45% to 85% RH However, dew condensation and freezing should be avoided.  
The storage temperature is ambient temperature during transportation or storage and should be within the usage temperature when starting to use the device.

## Mounting

### Direct mounting

- (1) The device should be mounted in a dry location low in dust and vibration.
- (2) The normal mounting direction is the direction shown in Fig. 1 on a vertical surface, but mounting the device at an inclination angle of up to 30 degrees in either direction is allowed. (Fig. 2)
- (3) Mounting the device on a floor or ceiling is not allowed. (Mounting the device on a floor or ceiling may affect the continuity performance, operation performance, and durability of the contact.)
- (4) If mounting the device in a horizontal orientation cannot be avoided, be sure to rotate the device by 90 degrees in a counterclockwise direction from the normal mounting direction as shown in figure 3 when mounting it.  
If the device is mounted in a horizontal orientation, its characteristic is nearly unchanged but mechanical durability may be deteriorated. Horizontal mounting of reversing type is not allowed.

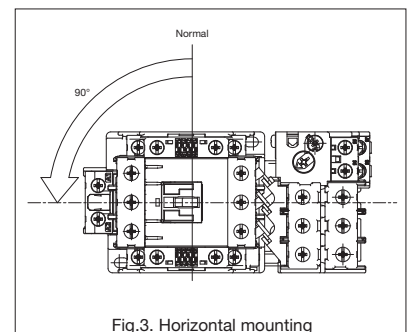
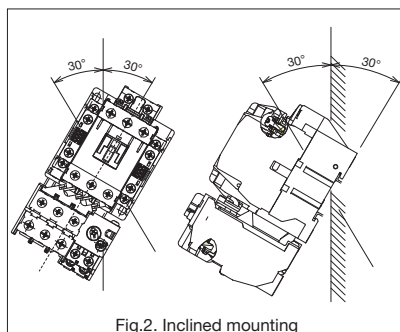
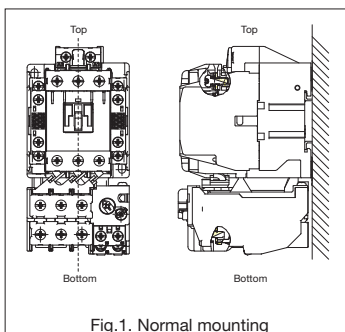

### Tightening torque of mounting screw

The device should be mounted by force of tightening torques shown in the right table.

Screw size	Tightening torque of mounting screw N·m
M4	1.2 to 1.9
M5	2.0 to 3.3

### Mounting of IEC 35mm wide rail

- The T10 to T80 types and SR-T type can be mounted on the IEC 35mm wide rail as a standard.
- DIN, EN, IEC, and JIS C2812 standards-compliant 35mm wide rails come in two types: 7.5mm and 15mm in rail height. Their shapes and dimensions are as shown in the figure below.

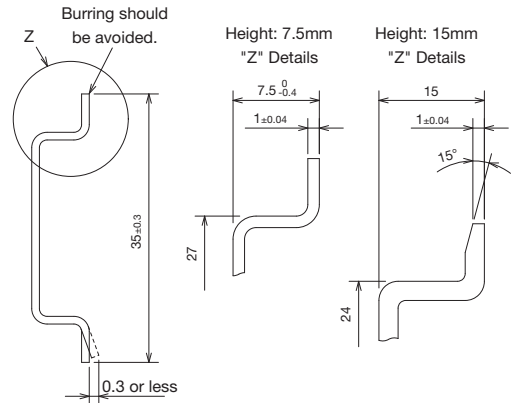

Rail	Rail specifications
1	TH35-7.5 Rail width: 35mm, Rail height: 7.5mm
2	TH35-15 Rail width: 35mm, Rail height: 15mm

- Maximum pitch of rail mounting screw L(mm)

When mounting a rail on a surface of the board, be sure to keep the rail mounting screw pitch below the dimension shown in the following table in order to secure sufficient mechanical strength.

Frame Rail	T10, T12, T20, T21, T25, T32, T35, T50, T65, T80	SR(D)-T5, T9
TH35-7.5	250	
TH35-15	500	

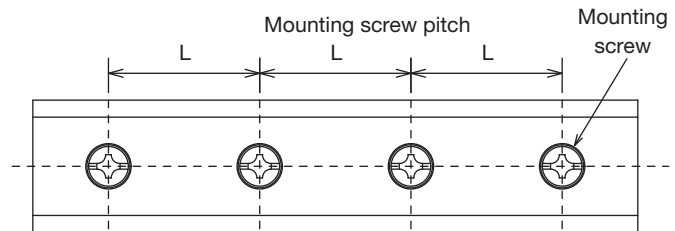

### Mounting space and arc space

When mounting the Magnetic Contactors side by side, be sure to keep the devices isolated by a distance longer than the dimension shown in the following table. Also, the Magnetic Contactors and adjacent grounding metal should be isolated by a distance longer than the dimension shown in the following table. The content described in ( ) is applied when additionally mounting auxiliary contacts. Although an arc space is not required in front of the Magnetic Contactors, providing a space longer than the E dimension shown in the following table is recommended in consideration of variation in the Magnetic Contactor's depth dimension, and vibration caused when turning on or releasing the contactor.

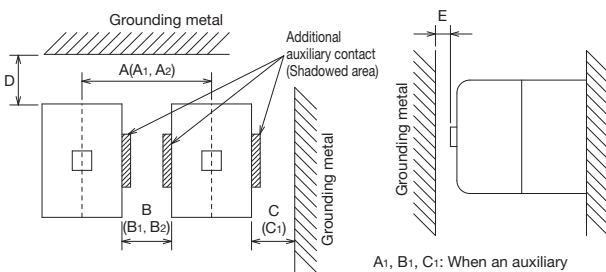

A<sub>1</sub>, B<sub>1</sub>, C<sub>1</sub>: When an auxiliary contact is added to the shadowed area  
 A<sub>2</sub>, B<sub>2</sub>: When two auxiliary contacts are added to the shadowed area

Mounting space and arc space

Frame	Minimum mounting space				Front arc space (Note 1)	Front mounting space E
	A(A <sub>1</sub> , A <sub>2</sub> ) dimension [mm]	B(B <sub>1</sub> , B <sub>2</sub> ) dimension [mm]	C (C <sub>1</sub> ) dimension [mm]	D dimension [mm]		
T10	41 (A <sub>1</sub> =53, A <sub>2</sub> =65)	5 (Note 2) (B <sub>1</sub> =17, B <sub>2</sub> =29)	10 (C <sub>1</sub> =22)	15	0	5 (Note 3)
T12	48 (A <sub>1</sub> =60, A <sub>2</sub> =72)					
T20	68 (A <sub>1</sub> =80, A <sub>2</sub> =92)					
T21	48 (A <sub>1</sub> =60, A <sub>2</sub> =72)					
T25	80 (A <sub>1</sub> =93.5, A <sub>2</sub> =107)	5 (Note 2) (B <sub>1</sub> =23.5, B <sub>2</sub> =32)	10 (C <sub>1</sub> =23.5)	25	0	5
T32	48 (A <sub>1</sub> =60, A <sub>2</sub> =72)					
T35	98 (A <sub>1</sub> =111.5, A <sub>2</sub> =125)	5 (Note 2) (B <sub>1</sub> =17, B <sub>2</sub> =29)	10 (C <sub>1</sub> =22)	15	0	10
T50	48 (A <sub>1</sub> =60, A <sub>2</sub> =72)					
T65	110 (A <sub>1</sub> =124, A <sub>2</sub> =138)	5 (Note 2) (B <sub>1</sub> =17, B <sub>2</sub> =29)	10 (C <sub>1</sub> =22)	15	0	5 (Note 3)
T80	48 (A <sub>1</sub> =60, A <sub>2</sub> =72)					
SR(D)-T5	48	5 (Note 2)	10	15	0	3
SR(D)-T9	48	5 (Note 2)	10	15	0	3

Note 1. The value of this arc space is a value of IEC and JIS Standards-based closed circuit shut-off capacity test.  
 Note 2. Although the B dimension of T10 to T32 allows closely-attached mounting, when continuing to apply current to the device or when mounting a product high in open/close frequency and high utilization on the same rail, the device life may be shortened in terms of temperature increase and impact, so please keep the space between the devices over the minimum value shown in the above table as much as possible when mounting them.  
 Note 3. E dimension is 3mm when mounting UT-AX2 or UT-AX4 with contactors.

## About Handling

## Note

### Connection

#### ● Applicable electric wire size and tightening torque and terminal dimension of terminal screw

⚠ This may cause overheating or fire. Be sure to properly keep the tightening torque and periodically re-tighten the screw.

However, please note that tightening the screw under the status where oil is adhered to the terminal portion may damage the terminal screw even within the existing tightening torque. Electric wires should be properly connected according to the electric wiring diagram. Tightening the terminal screw should be properly conducted within the tightening torque shown in the right table. Insufficient tightening of the terminal screw may cause overheating or cause the electric wire to drop off. Excessive tightening torque may damage the tightening screw. Adhesion of rock paint, thermo label, etc. to electric wire connection or contact may cause heat generation due to defective continuity, so this is very dangerous.

The main circuit terminals for the T10 to T50 and TH-T18 to T50 types can be wired connected by single wire, stranded wire or crimp lug. The main circuit terminals and operating circuit terminals of the T10 to T50 and TH-T18 to T50 types are self-lifting terminals that are easy to connect.

Model	Terminal dimension and size/type of screw			Applicable electric wire size [φmm, mm]	Connection conductor thickness (D) [mm]	Applicable crimp lug size (JST Cat No.)		Tightening torque of terminal screw [N·m]			
	Main circuit		Operating circuit			Main circuit		Operating circuit			
Standard type Contactor Relays Magnetic Contactors Thermal Overload Relays (Note 1)	Dimension of terminal portion A x B x C [mm] (Note 2)	Screw size	Screw type	cross slot screw with pressure plate	Main circuit	Operating circuit	Main circuit (Note 2)	Main circuit	Operating circuit	Main circuit	Operating circuit
SR-T5, T9	—	—	—	M3.5×7.6	—	—	—	—	—	—	—
S-T10, T12, T20	7.5×3.7×4.5	M3.5×7.6	cross slot screw with pressure plate	M3.5×7.6	φ1.6 0.75 to 2.5	φ1.6 0.75 to 2.5	1.6	1.25-3.5 to 2-3.5 5.5-S3	1.25-3.5 to 2-3.5	0.9 to 1.5	0.9 to 1.5
S-T21, T25, T32	10.5×5.2×5.5	M4×10.5		M3.5×7.6	φ1.6 to 2.6 1.25 to 6		3	1.25-4 to 5.5-4		1.2 to 1.9	
S-T35, T50	13.3×5.5×6.9	M5×14.8		M3.5×7.6	φ1.6 to 3.6 1.25 to 16		6	1.25-5 to 14-5 22-S5		2.0 to 3.3	
S-T65, T80	15×7×8.5	M6×12	cross-head/slotted-head screw	M4×10	(2 to 22)	φ1.6 0.75 to 2.5	3.7	1.25-6 to 22-6 38-S6 60-S6	1.25-4 to 2-4 5.5-S4	3.5 to 5.7	1.2 to 1.9
S-T100	15×7.5×11.5				(2 to 38)		4	1.25-6 to 60-6		3.5 to 5.7	
TH-T18 (Load side)	7.5×4×4	M3.5×7.6	cross slot screw with pressure plate	M3.5×7.6	φ1.6 0.75 to 2.5	φ1.6 0.75 to 2.5	2	1.25-3.5 to 2-3.5 5.5-S3	1.25-3.5 to 2-3.5	0.9 to 1.5	0.9 to 1.5
TH-T25 (Power side/Load side)	10.2×6.8×5/10.2×5.7×5	M4×10.5/ M4×10.5			φ1.6 to 2.6 1.25 to 6		2.5	1.25-4 to 5.5-4		1.2 to 1.9	
TH-T50 (Load side)	13.3×5.8×6.9	M5×14.8			φ2 to 3.6 4 to 14		8	5.5-5 to 14-5		2.0 to 3.3	
TH-T65	17×7.5×8.5	M6×12	cross-head/slotted-head screw	M4×10	(2 to 22) Note 3	φ1.6 1.25 to 2	4	5.5-6 to 22-6	1.25-4 to 2-4 5.5-S4	3.5 to 5.7	1.2 to 1.9
TH-T100 (Load side)	15×7.5×10	M6×12			(8 to 38) Note 3		3.7	14-6 to 22-6 38-S6		3.5 to 5.7	

Note 1: The dimension of the main circuit terminal is a dimension for board conductor wiring. (See the right diagram) The board conductor thickness (D dimension) must be below the allowable connection conductor thickness stated above because of the length of the terminal screw. In case of wiring with two boards used, the total value of two boards must be below the value (D dimension) shown in the table.

Note 2: In each terminal, two wires or two crimp lugs are allowed to be connected.

Note 3: The cross slot screws with pressure plate of T Series and those of N or other Series are same in size but different in pressure plate dimension, so please avoid the mixed use of such screws. This may break the insulation barrier or make the wire likely to fall out.

Note 4: When using IEC60529-based finger safe specification, be sure to use an insulation tube-attached crimp lug.

Note 5: Tightening the 3 terminal screw excessively without wiring may break the screw and consequently disable the tightening, so please avoid such excessive tightening.

Note 6: Operational circuits are coil terminals of Magnetic Contactors and control circuit terminals of Thermal Overload Relays.

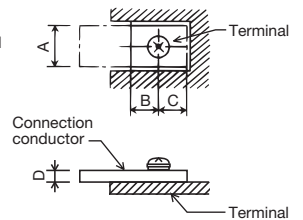

#### ● Application to a circuit exceeding 380V

- (1) When applying MSO, S-T10, T12, T20, MSOD/SD-T12, T20, SR(D)-T5, T9, and TH-T18 types to a circuit exceeding 380V to set a crimp lug wiring, please use an insulating tube-attached crimp lug.
- (2) When applying such parts to a Reversing type circuit exceeding 500V, please use an SR-T type Contactor Relays (XF, XR) as shown in the right figure to set the switching time allowance.

#### ● Wiring direction

Although the upper terminal side is usually set to the power supply side when wiring, the lower terminal side may be set to the power supply side when it is unavoidable due to some reason of the board wiring. **However, the mounting direction must be in accordance with the description on Page 14.**

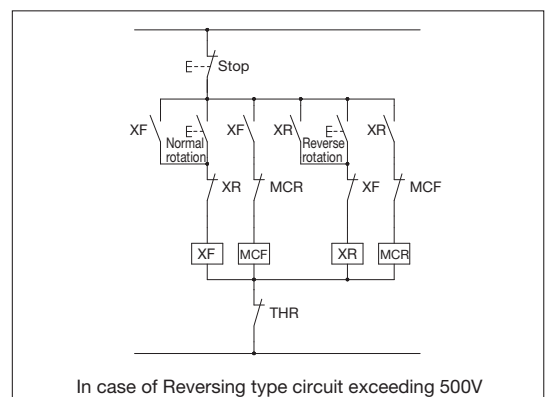



## Operating circuit

- ⚠ Applying a low voltage that does not operate the Magnetic Contactors to the operating circuit may cause overcurrent to the coil, which may cause the coil to be burned in a short time.
- ⚠ If the operating circuit wiring is too long, when the coil's instantaneous current flows, the wiring impedance may cause a reduction in the coil voltage, so that the operating circuit may fail to be activated. And, the stray capacitance of the wired line may cause the coil's excitation not to be released even when releasing the excitation.
- ⚠ Use in a circuit (inverter) with high harmonics and high frequency levels can burn the operation coil or surge absorber with CR in the S-T65 to T100 type Magnetic Contactors.

## Power supply voltage fluctuation range for operating circuit

### (1) Operating voltage

When the rated voltage and frequency are applied to the coil at an ambient temperature of 40°C (Inside temperature of the board: 55°C), the device operates without any problem at 85 to 110% of the rated voltage of the coil after the temperature increases and becomes saturated.

### (2) Voltage/Frequency and coil rating of operating circuit

The voltage/frequency of the operating circuit and the same of the operation coil must be matched.

Applying a voltage exceeding 100% of the rated voltage to the operating circuit when using the coil may acceleratedly deteriorate the coil insulation and consequently reduce mechanical durability, so set the coil's average voltage to 95 to 100% of the rated voltage when using the coil.

## Driving Magnetic Contactor with Triac control

The electromagnet in the S-T65 to T100 type Magnetic Contactor incorporates the capacitor-drop type AC operated DC excited method using the capacitor drop. Thus, a Triac with voltage resistance that is 2/2-fold the circuit voltage must be selected. If the Triac voltage resistance is low, use of a varistor in parallel with the Triac is recommended.

## Using with square wave power supply

The electromagnet in the S-T65 to T100 type Magnetic Contactor incorporates the AC operated DC exciting method using the capacitor drop. It cannot be used with a square wave as the coil's exciting current will increase greatly.

## Application to special environment

- ⚠ Please note that the operating characteristics of the Magnetic Contactor and Thermal Overload Relay may vary with the ambient temperature.

### High temperature

When using Magnetic Starters or Magnetic Contactors at high ambient temperature, the temperature may mainly affect the insulation life (continuous electric conduction life) of the operation coil and the aging variation of the molding component. MSO and S-T type without a box are standard products available even at the inside temperature of 55°C.

### Low temperature

Although the Magnetic Contactors may be transported to a cold region or used in such a cold region or under cold conditions such as those found in a refrigerator with the contactor incorporated in a switchboard, the S-T type Magnetic Contactors is applicable as a standard product. Also, MSO-T type Magnetic Starters and TH-T type Thermal Overload Relays of low temperature specification are not manufactured.

Low-temperature-based products: S-T□, S-2xT□ types

Applicable temperature range of low-temperature product: Operating temperature -50 to 55°C, Storage temperature -60 to 65°C

### Corrosive gas

S-T type Magnetic Contactors is of corrosion resistance-increased specification as a standard product.

Corrosive gases that exist in an environment with an Magnetic Starters or Magnetic Contactors used are gases such as sulfurous acid (SO<sub>2</sub>), hydrogen sulfide (H<sub>2</sub>S), chlorine (Cl<sub>2</sub>), and ammonia (NH<sub>3</sub>), and conductive portions can be protected by plating a metal resistant to such gases on the portion. However, because there is no adequate corrosion prevention method for the contact, such gases may increase the contact resistance, resulted in increased temperature.

Additionally, if the environment contains some corrosive gas but is under dry condition, this may delay the progression of corrosion, so using the switchboard with the inside kept as dry as possible is also one of the corrosion prevention methods.

In the Magnetic Starters and Thermal Overload Relays, corrosion-prevented products (MSO-T□YS, TH-T□YS) of the specification with increased corrosion resistance to such corrosive gases are also manufactured.

### Dust

Magnetic Starters and Magnetic Contactors used in an iron foundry, construction site, or powder conveying machine tend to be subject to a relatively large amount of dust. When using the control board in such locations, the board must be dust-prevention-structured. Also, using the board under hermetically-sealed condition for a long period may cause contact failure.

### Export of the products to tropical regions

The environment of exported products which pass through tropical regions tends to be of high temperature and high humidity, and humidity is the environmental factor that affects the Magnetic Starters and Magnetic Contactors most severely. Humidity is the biggest rust-generating factor and the exported products must be in a structure resistant to humidity. Therefore, it is recommended to put a moisture absorbent (Silica gel) in an amount of 3kg or more per m<sup>3</sup>; so as to lower the humidity.

## Specification List Table

### Magnetic Starters/Magnetic Contactors (AC operated)

Frame			T10	T12	T20	T21	
Applicable standard			JIS C8201-4-1, IEC60947-4-1, EN60947-4-1, GB14048.4				
Model name	Magnetic Contactors (Without Thermal Overload Relays, Open type)		Non-Reversing	S-T10	S-T12	S-T20	S-T21
			Reversing	S-2×T10	S-2×T12	S-2×T20	S-2×T21
	Magnetic Starters (With standard 2-element, With Thermal Overload Relays)	Enclosed	Non-Reversing	MS-T10	MS-T12	—	MS-T21
			Reversing	—	—	—	MS-2×T21
		Open type	Non-Reversing	MSO-T10	MSO-T12	MSO-T20	MSO-T21
	Reversing		MSO-2×T10	MSO-2×T12	MSO-2×T20	MSO-2×T21	
	Combined Thermal Overload Relays		TH-T18			TH-T25	
Magnetic Starters (With 3-element type Thermal Overload Relays)	Open type	Non-Reversing	MSO-T10KP	MSO-T12KP	MSO-T20KP	MSO-T21KP	
		Reversing	MSO-2×T10KP	MSO-2×T12KP	MSO-2×T20KP	MSO-2×T21KP	
	Combined Thermal Overload Relays		TH-T18KP			TH-T25KP	
Main contact rating	Rated insulation voltage [V]		690				
	Rated impulse withstand voltage [kV]		6				
	Rated frequency [Hz]		50/60				
	Pollution degree		3				
	Rated operational current / power Category AC-3 (Note 1) (Three-phase squirrel-cage motor load standard responsibility) (Note 2) [kW/A]	220 to 240VAC		2.5/11 [2.2/11]	3.5/13 [2.7/13]	4.5/18 [3.7/18]	5.5/25 [4/20]
		380 to 440VAC		4/9 [2.7/7]	5.5/12 [4/9]	7.5/18 [7.5/18]	11/23 [7.5/20]
		500VAC		4/7 [2.7/6]	5.5/9 [5.5/9]	7.5/17 [7.5/17]	11/17 [7.5/17]
		690VAC		4/5	5.5/7	7.5/9	7.5/9
	Rated operational current / power Category AC-4 (Three-phase squirrel-cage motor load inching responsibility) [kW/A]	220 to 240VAC		1.5/8	2.2/11	3.7/18	
		380 to 440VAC		2.2/6	4/9	5.5/13	
		500VAC		2.7/6	5.5/9	5.5/10	
Rated operational current / power Category AC-1 (Resistance, heater load)	100 to 240VAC		20			32	
	380 to 440VAC		11	13		32	
Conventional free air thermal current Ith [A]		20			32		
Minimum applicable load level		48V 200mA					
Auxiliary contact rating	Contact arrangement	Standard accessory	Non-Reversing	1a	1a1b	2a2b	
			Reversing (Note 4, Note 6)	1a×2+2b	1a1b×2+2b	2a2b×2	
		Special accessory	Non-Reversing	1b	2a	—	
			Reversing (Note 4, Note 6)	1b×2+2b	2a×2+2b	—	
		Max. number of additional options (Note 5)	Front clip-on	Non-Reversing	1		
				Reversing	2		
	Side clip-on	Non-Reversing	2				
		Reversing	2				
	Rated operational current (Category AC-15 : Alternating current coil load)		120VAC	6			
			240VAC	3			
Rated operational current (Category DC-13 : Direct current coil load)		24VDC	3				
		110VDC	0.6				
Conventional free air thermal current Ith [A]		10					
Minimum applicable load level		20V 3mA					
Performance	Mechanical durability [ten thousand times]		1000				
	Electrical durability [ten thousand times]	Category AC-3	200 (Note 9)				
		Category AC-4	3 (Note 9)				
		Category AC-1	50				
	Switching frequency [time/hour]	Category AC-3	1800				
Category AC-4		300					
Category AC-1		1200					
Characteristic	Coil consumption (Note 7)		Inrush [VA]	45		75	
			Sealed [VA]	7		7	
	Power consumption (Note 7) [W]		2.2			2.4	
Outside dimensions	Magnetic Contactors (without Thermal Overload Relays) (Width x Height x Depth) [mm]		Non-Reversing	36×75×78	43×75×78	63×81×81	
			Reversing	82×85×78	97×85×78	136×81×81	
	Open type Magnetic Starters (Width x Height x Depth) [mm]		Non-Reversing	45×115×79		63×128×82	
			Reversing	90×125×79	97×125×79	136×138×82	
	Enclosed Magnetic Starters (Width x Height x Depth) [mm]		Non-Reversing	76×165×97.5		104×176×110	
			Reversing	—		220×192×115	
IEC 35mm rail mounting			Possible (excluding Enclosed Magnetic Starters)				

Note 1: The figure in the square brackets indicates the rated current shown on the rating plate of the product at which the category AC-3 opening/closing durability is 2,000,000 times (1,000,000 times for the T20 380V). Refer to the electric durability curve for the life performance.

Note 2: The content within ( ) of rated capacity and rated operational current is applied to the Magnetic Contactor.

Note 3: The T10 to T50 types can be manufactured with a coil surge absorber-mounted type (□-□SA type). The UT-SA21 type can be mounted.

Note 4: +2b of T10 and T12 auxiliary contact arrangements in Reversing type represents b contact built in the UT-ML11 interlock unit.

Note 5: The main unit and auxiliary contact block must be prepared separately and additionally mounted by the user.

Note 6: For auxiliary contact arrangement in Reversing type, X2 is displayed as combined auxiliary contact arrangement of two Magnetic Contactors. Please specify the contact arrangement for which two main units are combined must be designated. <Designation example> In case of 1b x 2 + 2b: 2B

Note 7: Operational coil input and coil consumption are average values in case of applying 220V60Hz to AC200V coil.

Note 8: Refer to pages 36 for the mountable options.

Note 9: 1,000,000 times for T20 AC-3 Class 380V or higher, and 15,000 times for AC-4 Class. 15,000 times for T35 to T100 AC-4 Class 380V or higher.

	T25	T32	T35	T50	T65	T80	T100
	JIS C8201-4-1, IEC60947-4-1, EN60947-4-1, GB14048.4						
	S-T25	S-T32	S-T35	S-T50	S-T65	S-T80	S-T100
	S-2×T25	S-2×T32	S-2×T35	S-2×T50	S-2×T65	S-2×T80	S-2×T100
	MS-2×T25	—	MS-T35	MS-T50	MS-T65	MS-T80	MS-T100
	MS-T25	—	MS-2×T35	MS-2×T50	MS-2×T65	MS-2×T80	MS-2×T100
	MSO-T25	—	MSO-T35	MSO-T50	MSO-T65	MSO-T80	MSO-T100
	MSO-2×T25	—	MSO-2×T35	MSO-2×T50	MSO-2×T65	MSO-2×T80	MSO-2×T100
	TH-T25	—	TH-T25/T50	TH-T25/T50	TH-T65	TH-T65/T100	TH-T65/T100
	MSO-T25KP	—	MSO-T35KP	MSO-T50KP	MSO-T65KP	MSO-T80KP	MSO-T100KP
	MSO-2×T25KP	—	MSO-2×T35KP	MSO-2×T50KP	MSO-2×T65KP	MSO-2×T80KP	MSO-2×T100KP
	TH-T25KP	—	TH-T25/T50KP	TH-T25/T50KP	TH-T65KP	TH-T65/T100KP	TH-T65/T100KP
	690						
	6						
	50/60						
	3						
	7.5/30(26) [5.5/26]	7.5/32 [7.5/32]	11/40 [7.5/35]	15/55 [11/50]	18.5/65 [15/65]	22/85 [19/80]	30/105 [22/100]
	15/30(26) [11/25]	15/32 [15/32]	18.5/40 [15/32]	22/50 [22/50]	30/65 [30/65]	45/85 [37/80]	55/105 [45/93]
	15/24 [11/20]	15/24 [11/20]	18.5/32 [15/26]	25/38 [22/38]	37/60 [30/45]	45/75 [45/75]	55/85 [45/75]
	11/12	11/12	15/17	22/26	30/38	45/52	55/65
	4.5/20	5.5/26	5.5/26	7.5/35	11/50	15/65	19/80
	7.5/17	11/24	11/24	15/32	22/47	30/62	37/75
	7.5/12	7.5/13	11/17	15/24	22/38	30/45	37/55
	32		60	80	100	120	150
	32		60	80	100	120	150
	32		60	80	100	120	150
	48V 200mA						
	2a2b	—	2a2b	2a2b	2a2b	2a2b	2a2b
	2a2b×2	2a2b×2	2a2b×2	2a2b×2	2a2b×2	2a2b×2	2a2b×2
	—		—	—	—	—	—
	—		—	—	—	—	—
	1						
	2	—		2			—
	2						
	2	—		2			—
	6						
	3						
	3						
	0.6						
	10						
	20V 3mA						
	1000				500		
	200					100	
	3 (Note 9)						
	50						
	1800			1200			
	300						
	1200						600
	75	55	110	110	115	115	210
	7	4.5	10	10	20	20	23
	2.4	1.8	3.8	3.8	2.2	2.2	2.8
	63×81×81	43×81×81	75×89×91		88×106×106	88×106×106	100×124×127
	136×81×81	96×81×111	160×114×97		216×115×112	216×115×112	270×140×137
	63×128×82	—	75×157.5×91		90×158×106	90×174.5×106	100×196×127
	136×138×82	—	160×179×97		216×169×112	216×185.5×112	270×213×137
	—		135×231×126		160×282×145		190×317×163
	—		300×247×130		320×282×140		410×347×154
	Possible (excluding Enclosed Magnetic Starters)						

MS-T Series Introduction

Selection and Application

Application to Thermal Overload Relays

Product Introduction

Overseas Standard

Type Codes

Order Procedure

Outline Drawing

Warranty and Safety

## Specification List Table

### Magnetic Starters/Magnetic Contactors (DC operated)

Frame			T12	T20	T21	
Applicable standard			JIS C8201-4-1, IEC60947-4-1, EN60947-4-1, GB14048.4			
Model name	Magnetic Contactors (Without Thermal Overload Relays, Open type)	Non-Reversing	SD-T12	SD-T20	SD-T21	
		Reversing	SD-2×T12	SD-2×T20	SD-2×T21	
	Magnetic Starters (With standard 2-element, With Thermal Overload Relays)	Open type	Non-Reversing	MSOD-T12	MSOD-T20	MSOD-T21
		Reversing	MSOD-2×T12	MSOD-2×T20	MSOD-2×T21	
	Magnetic Starters (With 3-element type Thermal Overload Relays)	Combined Thermal Overload Relays	TH-T18			TH-T25
			Open type	Non-Reversing	MSOD-T12KP	MSOD-T20KP
Reversing	MSOD-2×T12KP	MSOD-2×T20KP	MSOD-2×T21KP			
Combined Thermal Overload Relays	TH-T18KP			TH-T25KP		
Main contact rating	Rated insulation voltage [V]		690			
	Rated impulse withstand voltage [kV]		6			
	Rated frequency [Hz]		50/60			
	Pollution degree		3			
	Rated operational current / power Category AC-3 (Note 1) (Three-phase squirrel-cage motor load standard responsibility) (Note 2) [kW/A]	220 to 240VAC	3.5/13 [2.7/13]	4.5/18 [3.7/18]	5.5/25 [4/20]	
		380 to 440VAC	5.5/12 [4/9]	7.5/18 [7.5/18]	11/23 [7.5/20]	
		500VAC	5.5/9 [5.5/9]	7.5/17 [7.5/17]	11/17 [7.5/17]	
	Rated operational current / power Category AC-4 (Three-phase squirrel-cage motor load inching responsibility) [kW/A]	220 to 240VAC	2.2/11	3.7/18		
		380 to 440VAC	4/9	5.5/13		
		500VAC	5.5/9	5.5/10		
	Rated operational current / power Category AC-1 (Resistance, heater load)	100 to 240VAC	20		32	
380 to 440VAC		13		32		
Conventional free air thermal current Ith [A]		20		32		
Minimum applicable load level		48V 200mA				
Auxiliary contact rating	Contact arrangement	Standard accessory	Non-Reversing	1a1b	2a2b	
			Reversing (Note 4, Note 6)	1a1b×2+2b	2a2b×2	
		Special accessory	Non-Reversing	2a	—	
			Reversing (Note 4, Note 6)	2a×2+2b	—	
		Max. number of additional options (Note 5)	H/O (head on)	Non-Reversing	1	
			Reversing	2		
	S/O (side on)	Non-Reversing	2			
		Reversing	2			
	Rated operational current (Category AC-15 : Alternating current coil load)		120VAC	6		
			240VAC	3		
	Rated operational current (Category AC-15 : Alternating current coil load)		24VDC	3		
		110VDC	0.6			
Conventional free air thermal current Ith [A]		10				
Minimum applicable load level		20V 3mA				
Performance	Mechanical durability [ten thousand times]		1000			
	Electrical durability [ten thousand times]	Category AC-3	200(Note 9)			
		Category AC-4	3(Note 9)			
		Category AC-1	50			
	Switching frequency [time/hour]	Category AC-3	1800			
		Category AC-4	300			
Category AC-1	1200					
Characteristic	Power consumption (Note 7) [W]		3.3 (2.2)		2.4	
Outside dimensions	Magnetic Contactors (without Thermal Overload Relays) (Width x Height x Depth) [mm]	Non-Reversing	43×75×100		63×81×108	
		Reversing	97×85×100		136×81×108	
	Open type Magnetic Starters (Width x Height x Depth) [mm]	Non-Reversing	45×115×101		63×128×109	
		Reversing	97×125×101		136×138×115	
IEC 35mm rail mounting			Possible			

Note 1: The figure in the square brackets indicates the rated current shown on the rating plate of the product at which the category AC-3 opening/closing durability is 2,000,000 times (1,000,000 times for the T20 380V). Refer to the electric durability curve for the life performance.

Note 2: The content within ( ) of rated capacity and rated operational current is applied to the Magnetic Starter.

Note 3: Coil surge absorber-mounted type (□-□ SA type) is also manufactured. UT-SA21 type is mounted.

Note 4: +2b of T10 and T12 auxiliary contact arrangements in Reversing type represents b contact built in the UT-ML11 interlock unit.

Note 5: The main unit and auxiliary contact block must be prepared separately and additionally mounted by the user.

Note 6: For auxiliary contact arrangement in Reversing type, X2 is displayed as combined auxiliary contact arrangement of two Magnetic Contactors. Please specify the contact arrangement for which two main units are combined must be designated. <Designation example> In case of 1b x 2 + 2b: 2B

Note 7: The above table shows the reference characteristics for a DC100V coil. The values in ( ) for SD-T12 to T32 indicate the reference characteristics for the DC12V and DC24V coils.

Note 8: Refer to pages 36 for the mountable options.

Note 9: 1,000,000 times for T20 AC-3 Class 380V or higher, and 15,000 times for T35 to T100 AC-4 Class 380V or higher.



	T32	T35	T50	T65	T80	T100
	JIS C8201-4-1, IEC60947-4-1, EN60947-4-1, GB14048.4					
	SD-T32	SD-T35	SD-T50	SD-T65	SD-T80	SD-T100
	SD-2×T32	SD-2×T35	SD-2×T50	SD-2×T65	SD-2×T80	SD-2×T100
	—	MSOD-T35	MSOD-T50	MSOD-T65	MSOD-T80	MSOD-T100
	—	MSOD-2×T35	MSOD-2×T50	MSOD-2×T65	MSOD-2×T80	MSOD-2×T100
	—	TH-T25/T50	TH-T25/T50	TH-T65	TH-T65/T100	TH-T65/T100
	—	MSOD-T35KP	MSOD-T50KP	MSOD-T65KP	MSOD-T80KP	MSOD-T100KP
	—	MSOD-2×T35KP	MSOD-2×T50KP	MSOD-2×T65KP	MSOD-2×T80KP	MSOD-2×T100KP
	—	TH-T25/T50KP	TH-T25/T50KP	TH-T65KP	TH-T65/T100KP	TH-T65/T100KP
	690					
	6					
	50/60					
	3					
	7.5/32 [7.5/32]	11/40 [7.5/35]	15/55 [11/50]	18.5/65 [15/65]	22/85 [19/80]	30/105 [22/100]
	15/32 [15/32]	18.5/40 [15/32]	22/50 [22/50]	30/65 [30/65]	45/85 [37/80]	55/105 [45/93]
	15/24 [11/20]	18.5/32 [15/26]	25/38 [22/38]	37/60 [30/45]	45/75 [45/75]	55/85 [45/75]
	5.5/26	5.5/26	7.5/35	11/50	15/65	19/80
	11/24	11/24	15/32	22/47	30/62	37/75
	7.5/13	11/17	15/24	22/38	30/45	37/55
	32	60	80	100	120	150
	32	60	80	100	120	150
	32	60	80	100	120	150
	48V 200mA					
	—	2a2b	2a2b	2a2b	2a2b	2a2b
	2a2b×2	2a2b×2	2a2b×2	2a2b×2	2a2b×2	2a2b×2
	—	—	—	—	—	—
	—	—	—	—	—	—
	1					
	—	2				—
	2					
	—	2				—
	6					
	3					
	3					
	0.6					
	10					
	20V 3mA					
	1000			500		
	200		100		100	
	3(Note 9)					
	50					
	1800		1200			
	300					
	1200					600
	1.8	9	9	18	18	24
	43×81×108	75×89×123		88×106×133	88×106×133	100×134×157
	96×81×138	160×114×129		216×115×139	216×115×139	270×147×167
	—	75×157.5×123		90×160×133	90×176.5×133	100×206×157
	—	160×179×129		216×169×139	216×185.5×139	270×213×167
	Possible					
	—					

MS-T Series Introduction

Selection and Application

Application to Thermal Overload Relays

Product Introduction

Overseas Standard

Type Codes

Order Procedure

Outline Drawing

Warranty and Safety

## Making and Breaking capacities

Frame		T10	T12	T20	T21	T25	T32	T35	T50	T65	T80	T100
Making capacity Category AC-3 [A]	220 to 240VAC	110	130	180	250	300	320	400	550	650	850	1050
	380 to 440VAC	90	120	180	230	300	320	400	500	650	850	1050
	500VAC	70	90	170	170	240	240	320	380	600	750	850
Breaking capacity Category AC-4 [A]	220 to 240VAC	88	104	144	200	240	256	320	440	520	680	840
	380 to 440VAC	72	96	144	184	240	256	320	400	520	680	840
	500VAC	56	72	136	136	192	192	256	304	480	600	680

## Coordination with short-circuit protective devices

Magnetic Contactors model			T10	T12	T20	T21	T25	T32	T35	T50	T65	T80	T100	SR-T5/T9
Type1	Short-circuit protective device rating * Fuse gG (IEC60269-1/2)	Main circuit	40A			80A			100A			125A	160A	—
		Auxiliary circuit	10A											10A

## Electrical Durability Curve

### Main circuit voltage 220 to 240VAC

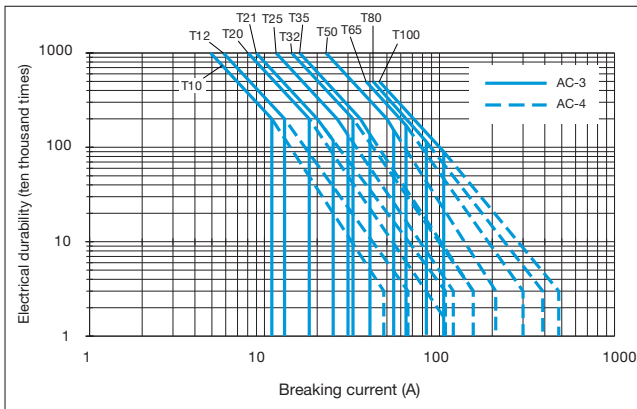

### Main circuit voltage 380 to 440VAC

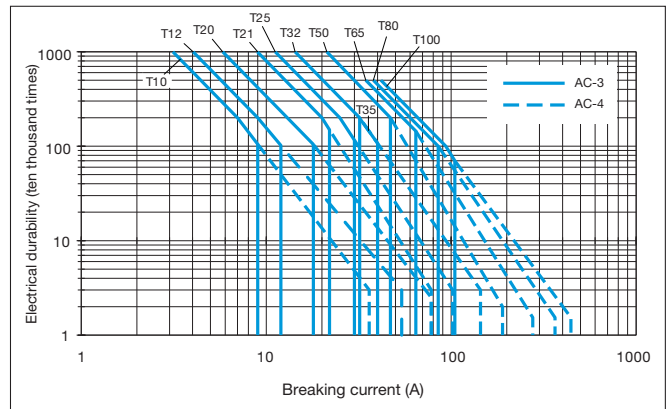

## Coil Ratings

### Coil types and ratings (Alternating voltage operation type)

#### For S-T10 to T100 types For SR-T5 and T9 types

Coil designation	Rated voltage [V]	Marking on the equipment
	50Hz/60Hz	
AC24V	24	Rated voltage and frequency
AC48V	48-50	
AC100V	100-127	
AC200V	200-240	
AC300V	260-300	
AC400V	380-440	
AC500V	460-550	

Note 1 : Even when the single rating (example: 200V60Hz) is specified for an order, the above rating voltage is indicated on the product.

Note 2 : Even when the single rating (example: 200V60Hz) is specified for an order, the above rating voltage is indicated on the product.

#### For S-T10SA to T50SA types For SR-T5SA and T9SA types

Coil designation	Rated voltage [V]	Coil indication	Varistor voltage [V]
	50Hz/60Hz		
AC24V	24	Rated voltage and frequency	120
AC48V	48-50		120
AC100V	100-127		470
AC200V	200-240		470
AC300V	260-300		910
AC400V	380-440		910

Note 1 : Add "SA" to the end of the type name to order the operation coil surge absorber mounting type (varistor). Example: S-T10SA AC100V

Note 2 : Even when the single rating (example: 200V60Hz) is specified for an order, the above rating voltage is indicated on the product.

## Coil types and ratings (DC operated type)

● For SD-T12 to T100 types  
For SRD-T5 and T9 types

Coil designation	Rated voltage	Coil indication
DC12V	DC12V	Rated voltage
DC24V	DC24V	
DC48V	DC48V	
DC100V	DC100V	
DC110V	DC110V	
DC125V	DC120-DC125V	
DC200V	DC200V	
DC220V	DC220V	

Note 1: The operating coil terminal has a polarity (excluding T35 to T100 types). Connect the positive side to terminal number A1 (+) and the negative side to A2 (-).

Note 2: If the operation power supply is a rectifier, open and close the coil on the DC side.

● For SD-T12SA to T50SA types  
For SRD-T5SA and T9SA types

Coil designation	Rated voltage	Coil indication	Varistor voltage [V]
DC12V	DC12V	Rated voltage	47
DC24V	DC24V		47
DC48V	DC48V		120
DC100V	DC100V		470
DC110V	DC110V		470
DC125V	DC120-125V		470
DC200V	DC200V		470
DC220V	DC220V		470

Note 1: If the type with surge absorber for operation coil (varistor) is required, add "SA" to the end of the model when placing your order. Example: SD-T21SA 100VDC

Note 2: The operating coil terminal has a polarity (excluding T35SA to T50SA types). Connect the positive side to terminal number A1 (+) and the negative side to A2 (-).

Note 3: Variations other than the above cannot be manufactured.

## Contact Reliability

### Contact reliability of main and auxiliary contacts

The minimum working voltage and current of the main and auxiliary contacts of the S-T type Magnetic Contactors and the contact of the SR-T type Contactor Relays vary depending on the allowable failure rate. Apply the following diagrams.

■ The contact reliability reduces when a contact is connected in series or when the current is applied and broken at the time of opening and closing the contact. Prescribe remedies such as connecting the contact in parallel (providing redundancy).

■ If a reliability higher than the contact reliability given in Diagram 1 to Diagram 4 is required, the contacts must be connected in parallel (redundant).

● Magnetic Contactors

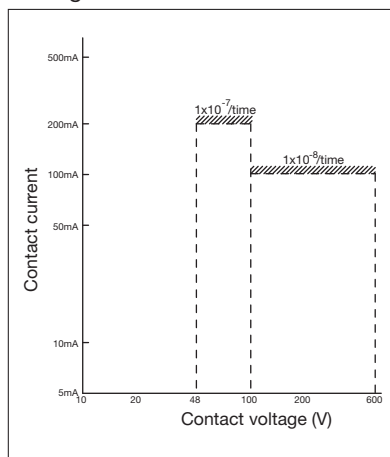

Diagram 1. S(D)-T main contact

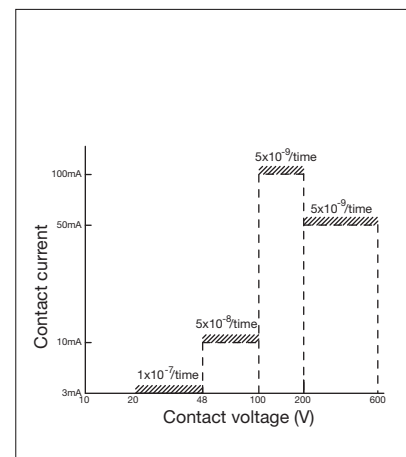

Diagram 2 S(D)-T, UT-AX11 auxiliary contacts

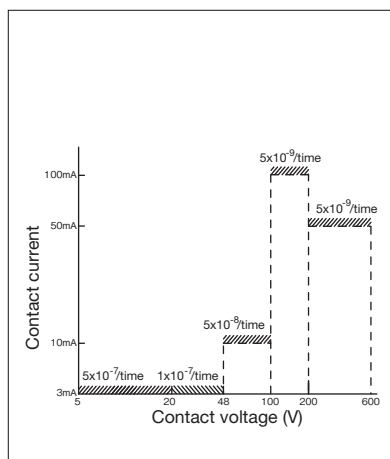

Diagram 3 UT-AX2/4 auxiliary contact

● Contactor Relays

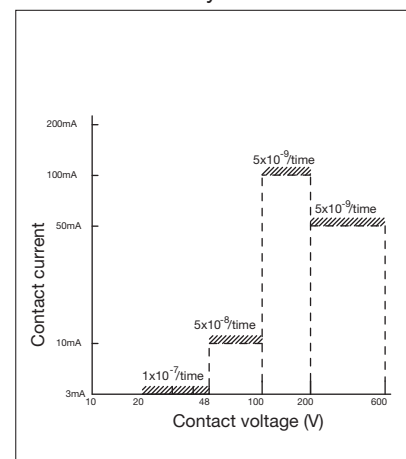

Diagram 4. SR(D)-T5, T9

Note 1: The contact reliability indicates the failure rate  $\lambda 60$  (the number of failures/the number of opening and closing operations, per contact) at 60% reliability standard.



This reliability is applied when the product is in use under a clean atmosphere in the standard specification environment (Refer to page 14).

Note 2: The contact resistance of the contacts may change due to economical corrosion and that may affect the contacts in the case of a light load.

It is recommended that regular inspections to be conducted, with load opening and closing performed several times in the inspection, and that consideration be provided on the system side.

## Specification List

### Model list

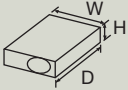
Frame			T18	T25		
Appearance						
Model name	with 2-elements	For Magnetic Starters For independent mounting	TH-T18 -	TH-T25		
	with 3-elements	For Magnetic Starters For independent mounting	TH-T18KP -	TH-T25KP		
	Outside dimensions [mm]	For Magnetic Starters	45×55×76.5	63×51×79		
	W×H×D	For independent mounting	-	-		
	Product weight [kg]	For Magnetic Starters	0.11	0.16		
		For independent mounting	-	-		
Applicable standard			IEC60947-4-1, EN60947-4-1, JIS C8201-4-1, GB14048.4			
Use condition		Ambient temperature [°C]	-10 to +40 (Standard: 20°C; maximum temperature on the board: 55°C)			
		Frequency [Hz]	0(DC) to 400			
Main circuit specifications	Rated insulation voltage [V]		690			
	Rated impulse withstand voltage [kV]		6			
	Pollution degree		3			
	Heater designation (adjustable range of stabilized current) [A] (Rated operational voltage : 550V maximum)		0.12 (0.1 to 0.16)	2.1 (1.7 to 2.5)	0.24 (0.2 to 0.32)	2.5 (2 to 3)
			0.17 (0.14 to 0.22)	2.5 (2 to 3)	0.35 (0.28 to 0.42)	3.6 (2.8 to 4.4)
			0.24 (0.2 to 0.32)	3.6 (2.8 to 4.4)	0.5 (0.4 to 0.6)	5 (4 to 6)
			0.35 (0.28 to 0.42)	5 (4 to 6)	0.7 (0.55 to 0.85)	6.6 (5.2 to 8)
			0.5 (0.4 to 0.6)	6.6 (5.2 to 8)	0.9 (0.7 to 1.1)	9 (7 to 11)
			0.7 (0.55 to 0.85)	9 (7 to 11)	1.3 (1 to 1.6)	11 (9 to 13)
			0.9 (0.7 to 1.1)	11 (9 to 13)	1.7 (1.4 to 2)	15 (12 to 18)
1.3 (1 to 1.6)			15 (12 to 18)	2.1 (1.7 to 2.5)	22 (18 to 26)	
1.7 (1.4 to 2)						
Power consumption [VA/element] at minimum/maximum stabilization		0.8 / 1.8		1.5 / 3.0		
Terminal screw size		M3.5		M4		
Compatible with terminal	Electric wire size [mm <sup>2</sup> ]	φ 1.6, 0.75 to 2.5		φ 1.6 to 2.6, 1.25 to 6		
	Crimp lug size	1.25-3.5 to 2-3.5, 5.5-S3		1.25-4 to 5.5-4		
Contact arrangement			1a1b			
Conventional free air thermal current Ith [A]			2			
Operation circuit (contact) specifications	Rating Operational Current [A]	Category AC-15 (AC operated Magnetic Contactors) Coil opening and closing a contact/b contact	24VAC	2(0.5) / 2(0.5)	2(0.5) / 3(0.5)	
			120VAC	2(0.5) / 2(0.5)	2(0.5) / 3(0.5)	
			240VAC	1(0.5) / 1(0.5)	1(0.5) / 2(0.5)	
		550VAC	0.3(0.3) / 0.3(0.3)	0.3(0.3) / 0.3(0.3)		
		Category DC-13 (DC operated Magnetic Contactors) Coil opening and closing	24VDC	0.5(0.3)	1(0.3)	
			110VDC	0.2(0.2)	0.2(0.2)	
		220VDC	0.1(0.1)	0.1(0.1)		
Minimum applicable load level			20V 5mA			
Terminal screw size			M3.5			
Compatible with terminal	Electric wire size [mm <sup>2</sup> ]	φ 1.6, 0.75 to 2.5		φ 1.6, 0.75 to 2.5		
	Crimp lug size	1.25-3.5 to 2-3.5		1.25-3.5 to 2-3.5		
Trip class			10A			
Operating characteristic curve description page			Page 27			
Vibration resistance (vibration resistance malfunction performance)			10 to 55 Hz, 19.6 m/s <sup>2</sup>			
Trip-free			○			
Reset method			Manual/Automatic switchable			
Operation indication (lever indication)			○			
Manual trip check			○			
Applied products	With saturable reactor		TH-□SR			
	With 3-element (2E) thermal saturable reactor		TH-□KPSR			
	2-element quick-acting characteristics thermal		TH-□FS			
	With 3-element (2E) thermal quick-acting characteristics		TH-□FSKP			

Note 1: The ambient temperature compensator is mounted on all types.



## Thermal Overload Relays

## Model list

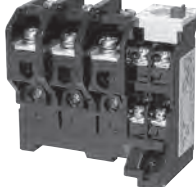
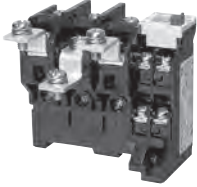
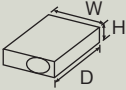
Frame			T50	T65	T100
Appearance					
Model name	with 2-elements	For Magnetic Starters For independent mounting	TH-T50 —	TH-T65	TH-T100 —
	with 3-elements	For Magnetic Starters For independent mounting	TH-T50KP —	TH-T65KP	TH-T100KP —
	Outside dimensions [mm] W×H×D	For Magnetic Starters For independent mounting	74.3×72×83.5 —	89×57×83.5	89×73.5×83.5 —
	Product weight [kg]	For Magnetic Starters For independent mounting	0.2 —	0.26	0.32 —
Applicable standard			IEC60947-4-1, EN60947-4-1, JIS C8201-4-1, GB14048.4		
Use condition		Ambient temperature [°C] Frequency [Hz]	-10 to +40 (Standard: 20°C; maximum temperature on the board: 55°C) 0(DC) to 400		
Main circuit specifications	Rated insulation voltage [V]		690		
	Rated impulse withstand voltage [kV]		6		
	Pollution degree		3		
	Heater designation (adjustable range of stabilized current) [A] (Rated operational voltage : 550V maximum)		29 (24 to 34) 35 (30 to 40) 42 (34 to 50)	15 (12 to 18) 22 (18 to 26) 29 (24 to 34) 35 (30 to 40) 42 (34 to 50) 54 (43 to 65)	67 (54 to 80) 82 (65 to 100)
	Power consumption [VA/element] at minimum/maximum stabilization		1.6/3.2      2.4/5.5      2.5/6.0		
	Terminal screw size		M5      M6      M6		
	Compatible with terminal	Electric wire size [mm <sup>2</sup> ]	φ5.5 to 14      —      —		
		Crimp lug size	5.5-5 to 14-5      5.5-6 to 22-6      14-6 to 22-6, 38-S6		
	Contact arrangement		1a1b      1a1b      1a1b		
	Conventional free air thermal current I <sub>th</sub> [A]		5      5      5		
Rating Operational Current [A]	Category AC-15 (AC operated Magnetic Contactors) (Coil opening and closing a contact/b contact The value in brackets indicates the rating for automatic reset.	24VAC	2(0.5) / 3(0.5)	2(0.5) / 3(0.5)	2(0.5) / 3(0.5)
		120VAC	2(0.5) / 3(0.5)	2(0.5) / 3(0.5)	2(0.5) / 3(0.5)
240VAC		1(0.5) / 2(0.5)	1(0.5) / 2(0.5)	1(0.5) / 2(0.5)	
550VAC		0.3(0.3) / 0.3(0.3)	0.5(0.5) / 1(0.5)	0.5(0.5) / 1(0.5)	
Current [A]	Category DC-13 (DC operated Magnetic Contactors) (Coil opening and closing The value in brackets indicates the rating for automatic reset.	24VDC	1(0.3)	1(0.3)	1(0.3)
		110VDC	0.2(0.2)	0.2(0.2)	0.2(0.2)
		220VDC	0.1(0.1)	0.1(0.1)	0.1(0.1)
Minimum applicable load level		20V 5mA      20V 5mA      20V 5mA			
Terminal screw size		M3.5      M4      M4			
Compatible with terminal	Electric wire size [mm <sup>2</sup> ]	φ 1.6, 1.25 to 2      φ 1.6, 1.25 to 2      φ 1.6, 1.25 to 2			
	Crimp lug size	1.25-3.5 to 2-3.5      1.25-4 to 2-4, 5.5-S4      1.25-4 to 2-4, 5.5-S4			
Trip class		10A      15 to 42A:10      54A:10A      67A:10      82A:10A			
Operating characteristic curve description page		Page 27			
Vibration resistance (vibration resistance malfunction performance)		10 to 55Hz      19.6m/s <sup>2</sup>			
Trip-free		○      ○      ○			
Reset method		Manual/Automatic switchable      Manual/Automatic switchable      Manual/Automatic switchable			
Operation indication (lever indication)		○      ○      ○			
Manual trip check		○      ○      ○			
Applied products	With saturable reactor	TH-□SR	○(TH-T50SR)	○(TH-T65SR)	○(TH-T100SR)
	With 3-element (2E) thermal saturable reactor	TH-□KPSR	○(TH-T50KPSR)	○(TH-T65KPSR)	○(TH-T100KPSR)
	2-element quick-acting characteristics thermal	TH-□FS	○(TH-T50FS)	○(TH-T65FS)	○(TH-T100FS)
	With 3-element (2E) thermal quick-acting characteristics	TH-□FSKP	○(TH-T50FSKP)	○(TH-T65FSKP)	○(TH-T100FSKP)

Note 1: The ambient temperature compensator is mounted on all types.

## Selection Table

Thermal Overload Relays

### Application to standard three-phase motor of Thermal Overload Relays

Thermal Overload Relays				Standard three-phase motor capacity [kW]		Magnetic Contactors that can be combined				
Heater designation(A)	Setting range(A)	Short-circuit protector rating (A) * Fuse gG (IEC60269-1/2)		200-220V	380-440V	TH-T18	TH-T25	TH-T50	TH-T65	TH-T100
		Main circuit	Auxiliary circuit							
0.12	0.1-0.16	2	6							
0.17	0.14-0.22	2	6							
0.24	0.2-0.32	2	6							
0.35	0.28-0.42	2	6							
0.5	0.4-0.6	2	6							
0.7	0.55-0.85	4	6							
0.9	0.7-1.1	4	6							
1.3	1.0-1.6	4	6							
1.7	1.4-2.0	6	6							
2.1	1.7-2.5	6	6							
2.5	2.0-3.0	10	6							
3.6	2.8-4.4	10	6							
5	4.0-6.0	16	6							
6.6	5.2-8.0	20	6							
9	7.0-11	20	6							
11	9.0-13	25	6							
15	12-18	32	6							
22	18-26	50	6							
29	24-34	63	6							
35	30-40	100	6							
42	34-50	100	6							
54	43-65	100	6							
67	54-80	125	6							
82	65-100	160	6							

## Precautions for Use

Thermal Overload Relays

### Disassembly

The Thermal Overload Relays are adjusted at the time of assembly. Do not disassemble it.

### Ambient temperature compensation

The TH-T type Thermal Overload Relays are adjusted with the Magnetic Starters in the standard box (the MS type) relative to the ambient temperature of 20°C (The temperature on the control board of the MSO type Magnetic Starters is 35°C). The ambient temperature compensator is mounted on the TH-T type Thermal Overload Relays. Therefore, the ambient temperature less affects the operational characteristic change. The minimum operating current change according to the ambient temperature change relative to the ambient temperature of 20°C (the temperature on the control board of 35°C) generally depends on the characteristics in the diagrams 1 and 2.

The Thermal Overload Relays have a characteristic that the operating current becomes high when the ambient temperature is low and becomes low when the ambient temperature is high. If the ambient temperature of the installation site is significantly different from 20°C (the temperature on the control board of 35°C), the setting current of the Thermal Overload Relays needs to be corrected as shown in diagrams 1 and 2. In addition, note that the compensation factor has a characteristic to be the minimum scale>middle scale>maximum scale at the adjustment knob location. (Note that the Thermal Overload Relays may operate at a current of less than 100% stabilized current if in use at temperatures exceeding the allowable working temperature of 40°C (55°C).)

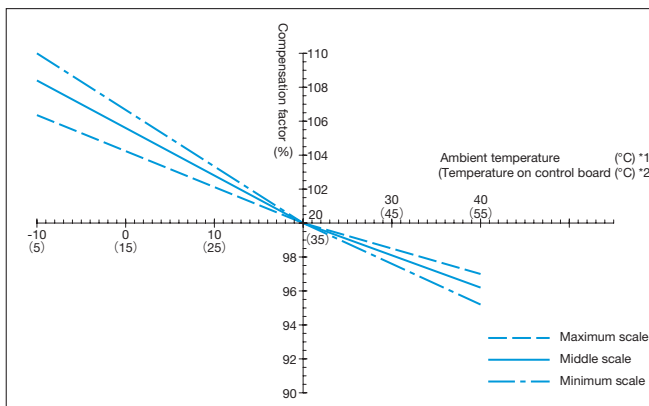

Diagram 1. Ambient temperature compensation curve (T18 frame)

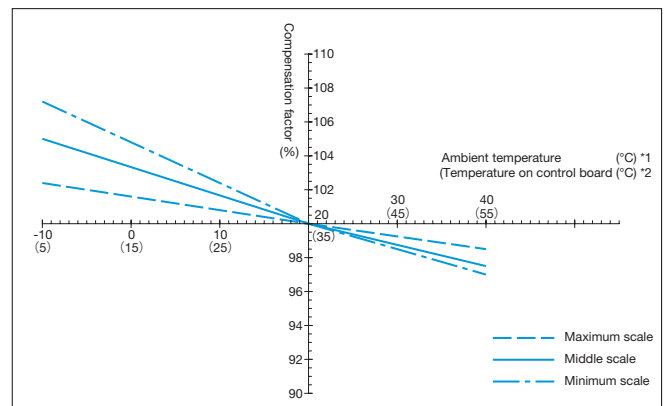

Diagram 2. Ambient temperature compensation curve (T25, T50, T65, T100 frame)

Compensation factor: Percentage of the minimum operating current at the ambient temperature of 20°C (the temperature on the control board of 35°C)

<Compensation procedure of setting current>

Determine the compensation factor of the working ambient temperature according to the curves in diagrams 1 and 2 and use the value of all load currents of the motor divided by the determined compensation factor as the stabilization value.

Example: The ambient temperature compensation factor for TH-T25 at the ambient temperature of 40°C (the temperature on the control board of 55°C) is 97% at the minimum scale according to diagram 2. If the motor rated current is 15A, the stabilization value is 15.5A (=15/0.97).

Note 1: [\*1] The ambient temperature applied to the MS type indicates the outside temperature of the box.

[\*2] The temperature including temperature increase on the control board applied to the MSO type is indicated.

## Connecting electric wire size and operating current

The TH-T type adjusts the minimum operating current with the standard electric wire size shown in the following table. If the electric wire is thicker or thinner than this standard electric wire size, the operating current becomes high or low, respectively. Therefore, correct the stabilized current (divide it by the change rate of the minimum operating current) to use a size different from the standard connecting electric wire size.

Model name	Heater designation [A]	Standard electric wire size [mm <sup>2</sup> ]	Connecting electric wire size [mm <sup>2</sup> ]		Change rate of minimum operating current [%]	
TH-T18(KP)	0.12 to 15	2	1.25	2.5	98	103
TH-T25(KP)	0.24 to 11	3.5	2	6	97	104
TH-T50(KP)	15, 22	8	5.5	14	96	104
	29					
	35	14	8	95		
TH-T65(KP)	15	3.5	2	5.5	95	105
	22, 29	5.5	3.5	8	96	105
	35	8	5.5	14	95	105
	42	14	8	22	95	104
	54	22	14	30	96	104
TH-T100(KP)	67	22	14	30	97	103
	82	38	30		97	

## Operating Characteristic of Thermal Overload Relays (Ambient Temperature of 20°C) Thermal Overload Relays

For the information on the connecting electric wire size, refer to page 16.

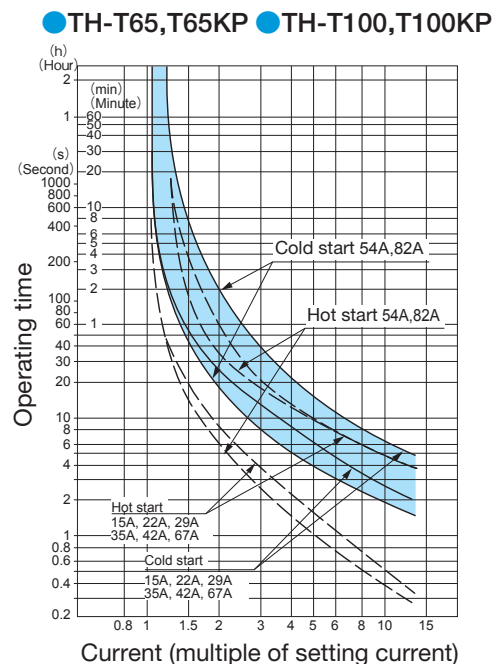
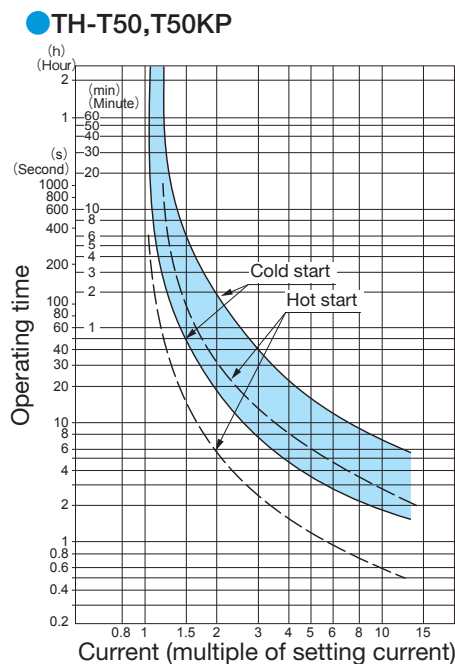
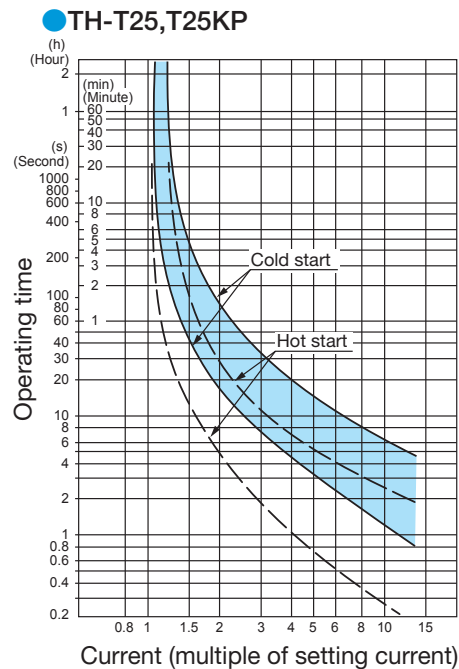
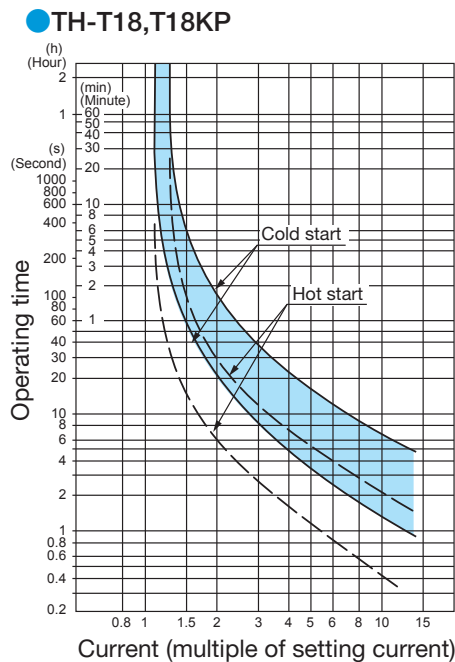

## Operating Characteristic of Thermal Overload Relays (Ambient Temperature of 20°C)

● TH-T18SR

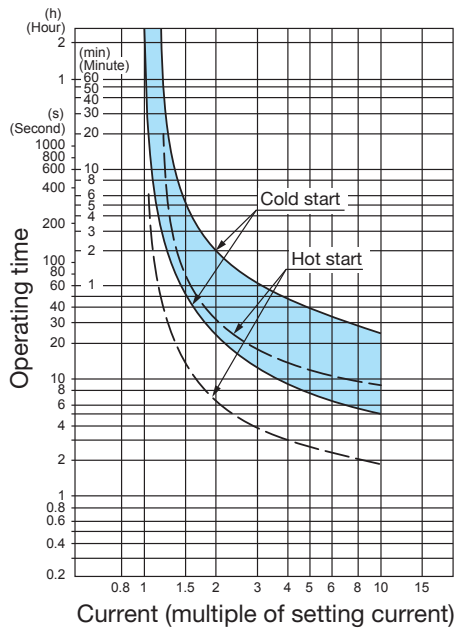

● TH-T25SR, T25KPSR

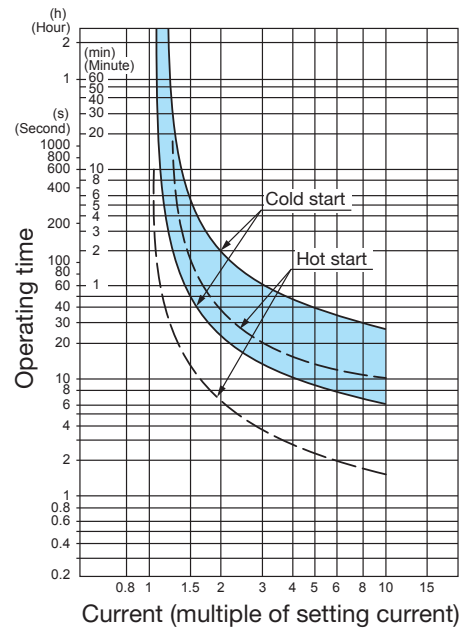

● TH-T50SR, T50KPSR

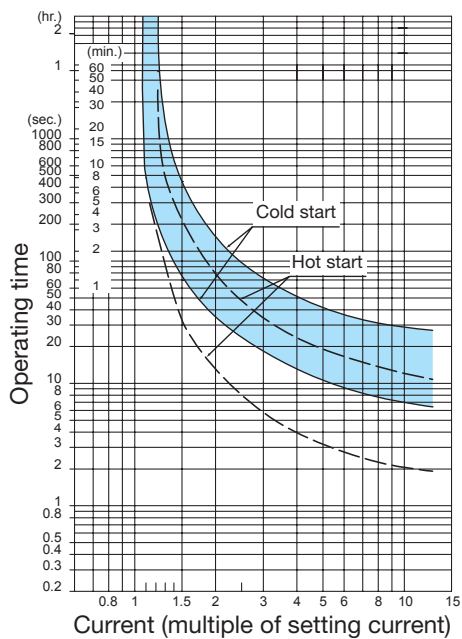

● TH-T65SR, T65KPSR  
● TH-T100SR, T100KPSR

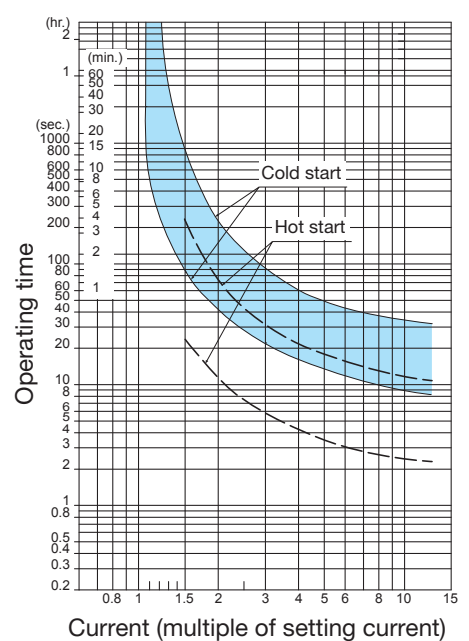

Thermal Overload Relays

● TH-T18FSKP

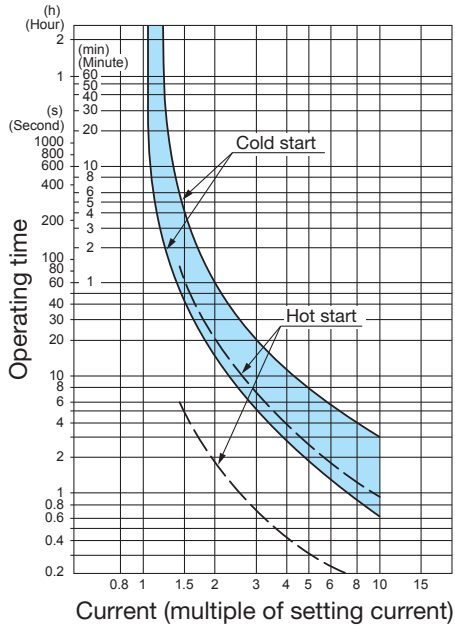

● TH-T25FS, TH-T25FSKP  
● TH-T50FS, T50FSKP

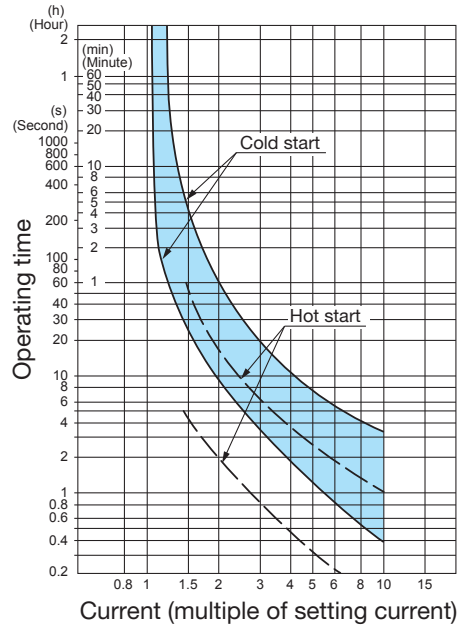

● TH-T65FS, T65FSKP  
● TH-T100FS, T100FSKP

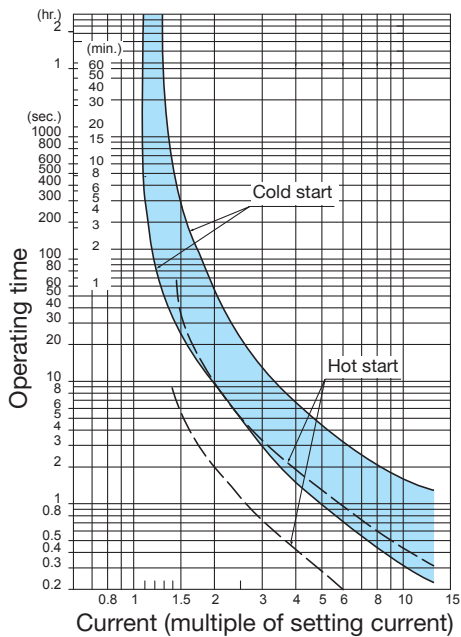

## Magnetic Starters

- MS-T series (non-Reversing) : Enclosed
- MS-2xT series (Reversing) : Enclosed

Model name	Non-reversing	MS-T10	MS-T12	MS-T21	MS-T25	MS-T35	MS-T50	MS-T65	MS-T80	MS-T100		
	Reversing	—	—	MS-2XT21	MS-2XT25	MS-2XT35	MS-2XT50	MS-2XT65	MS-2XT80	MS-2XT100		
Rated capacity (kW)	220 to 240VAC	2.5[2.2]	3.5[2.7]	5.5[4]	7.5[5.5]	11[7.5]	15[11]	18.5[15]	22[19]	30[22]		
Category AC-3 (Note 1)	380 to 440VAC	4[2.7]	5.5[4]	11[7.5]	15[11]	18.5[15]	22[22]	30[30]	45[37]	55[45]		
	500VAC	4[2.7]	5.5[5.5]	11[7.5]	15[11]	18.5[15]	22[22]	37[30]	45[45]	55[45]		
Heater rating (designation) of standard Thermal Overload Relays (A)		0.12 0.17 0.24 0.35 0.5 0.7 0.9 1.3 1.7 2.1 2.5 3.6 5 6.6 9	0.12 0.17 0.24 0.35 0.5 0.7 0.9 1.3 1.7 2.1 2.5 3.6 5 6.6 9	0.24 0.35 0.5 0.7 0.9 1.3 1.7 2.1 2.5 3.6 5 6.6 9 11 15 22	0.24 0.35 0.5 0.7 0.9 1.3 1.7 2.1 2.5 3.6 5 6.6 9 11 15 22	0.24 0.35 0.5 0.7 0.9 1.3 1.7 2.1 2.5 3.6 5 6.6 9 11 15 22 29 35	0.24 0.35 0.5 0.7 0.9 1.3 1.7 2.1 2.5 3.6 5 6.6 9 11 15 22 29 35 42	15 22 29 35 42 54 67 82	15 22 29 35 42 54 67 82	15 22 29 35 42 54 67 82		
Operation coil rating	Refer to page 22											
Auxiliary contact arrangement	Non-Reversing	Standard	1a	1a1b	2a2b							
		Special	1b	2a	—							
	Reversing	Standard	—		2a2bx2							
		Special	—		—							
 (unit: mm)	Non-reversing	A	165		176		231		282		317	
		B	76		104		135		160		190	
		C	97.5		110		126		145		163	
	Reversing	A	—		192		247		282		347	
		B	—		220		300		320		410	
		C	—		115		130		140		154	

Note 1: The figure in the square brackets indicates the rated current shown on the rating plate of the product at which the category AC-3 opening/closing durability is 2,000,000 times (1,000,000 times for the T20 380V). Refer to the electric durability curve for the life performance.

- MSO-T series (non-Reversing) : Open type
- MSO-2xT series (Reversing) : Open type

Model name	Non-Reversing	MSO-T10	MSO(D)-T12	MSO(D)-T20	MSO(D)-T21	MSO-T25	
	Reversing	MSO-2xT10	MSO(D)-2xT12	MSO(D)-2xT20	MSO(D)-2xT21	MSO-2xT25	
Rated capacity (kW)	220 to 240VAC	2.5[2.2]	3.5[2.7]	4.5[3.7]	5.5[4]	7.5[5.5]	
Category AC-3 (Note 1)	380 to 440VAC	4[2.7]	5.5[4]	7.5[7.5]	11[7.5]	15[11]	
	500VAC	4[2.7]	5.5[5.5]	7.5[7.5]	11[7.5]	15[11]	
Heater rating (designation) of standard Thermal Overload Relays (A)		0.12 0.17 0.24 0.35 0.5 0.7 0.9 1.3 1.7 2.1 2.5 3.6 5 6.6 9	0.12 0.17 0.24 0.35 0.5 0.7 0.9 1.3 1.7 2.1 2.5 3.6 5 6.6 9 11	0.12 0.17 0.24 0.35 0.5 0.7 0.9 1.3 1.7 2.1 2.5 3.6 5 6.6 9 11 15	0.24 0.35 0.5 0.7 0.9 1.3 1.7 2.1 2.5 3.6 5 6.6 9 11 15 22	0.24 0.35 0.5 0.7 0.9 1.3 1.7 2.1 2.5 3.6 5 6.6 9 11 15 22	
Operation coil rating	Refer to pages 22						
Auxiliary contact arrangement	Non-Reversing	Standard	1a	1a1b	1a1b	2a2b	2a2b
		Special	1b	2a	2a	—	—
	Reversing	Standard	1a×2+2b	1a1b×2+2b	1a1b×2+2b	2a2b×2	2a2b×2
		Special	1b×2+2b	2a×2+2b	2a×2+2b	—	—
 (unit: mm)	Non-Reversing	A	115	115	115	128	128
		B	45	45	45	63	63
		C	79	79(101)	79(101)	82(109)	82
	Reversing	A	125	125	125	138	138
		B	90	97	97	136	136
		C	79	79(101)	79(101)	82(115)	82
IEC 35mm rail mounting type	←—————→						
Option	Front clip-on auxiliary contact block mounting type	←—————→					
	Side clip-on auxiliary contact block mounting type	←—————→					
	Surge absorber mounting type	←—————→					
		←—————→					

Note 1: The figure in the square brackets indicates the rated current shown on the rating plate of the product at which the category AC-3 opening/closing durability is 2,000,000 times (1,000,000 times for the T20 380V). Refer to the electric durability curve for the life performance.

Model name		Non-Reversing	MSO (D) -T35	MSO (D) -T50	MSO (D) -T65	MSO (D) -T80	MSO (D) -T100
		Reversing	MSO (D) -2×T35	MSO (D) -2×T50	MSO (D) -2×T65	MSO (D) -2×T80	MSO (D) -2×T100
Rated capacity (kW) Category AC-3 (Note 1)	220 to 240VAC		11[7.5]	15[11]	18.5[15]	22[19]	30[22]
	380 to 440VAC		18.5[15]	22[22]	30[30]	45[37]	55[45]
	500VAC		18.5[15]	22[22]	37[30]	45[45]	55[45]
Heater rating (designation) of standard Thermal Overload Relays (A)			0.24 0.35 0.5 0.7 0.9 1.3 1.7 2.1 2.5 3.6 5 6.6 9 11 15 22 29 35	0.24 0.35 0.5 0.7 0.9 1.3 1.7 2.1 2.5 3.6 5 6.6 9 11 15 22 29 35 42	15 22 29 35 42 54	15 22 29 35 42 54 67 82	15 22 29 35 42 54 67 82 95
Operation coil rating			Refer to pages 22				
Auxiliary contact arrangement	Non-Reversing	Standard	2a2b	2a2b	2a2b	2a2b	2a2b
		Special	—	—	—	—	—
	Reversing	Standard	2a2b×2	2a2b×2	2a2b×2	2a2b×2	2a2b×2
		Special	—	—	—	—	—
 (unit: mm)		Non-Reversing	A	157.5	158(160)	174.5(176.5)	196(206)
		B	75	90	90	100	
		C	91(123)	106(133)	106(133)	127(157)	
		Reversing	A	179	169	185.5	213
		B	160	216	216	270	
		C	97(129)	112(139)	112(139)	137(167)	
IEC 35mm rail mounting type			←————→				—
Option	Front clip-on auxiliary contact block mounting type		←————→				—
	Side clip-on auxiliary contact block mounting type		←————→				—
	Surge absorber mounting type		←————→				—

Note 1: The figure in the square brackets indicates the rated current shown on the rating plate of the product at which the category AC-3 opening/closing durability is 2,000,000 times (1,000,000 times for the T20 380V). Refer to the electric durability curve for the life performance.

### ● Thermal Overload Relays configuring the Magnetic Starters

Thermal Overload Relays models and heater types that configure Magnetic Starters

Magnetic Contactors frame	Thermal Overload Relays model	Heater designation (adjustable range of stabilized current) (A)
T10, T12, T20	TH-T18	0.12(0.1 to 0.16), 0.17(0.14 to 0.22), 0.24(0.2 to 0.32), 0.35(0.28 to 0.42), 0.5(0.4 to 0.6), 0.7(0.55 to 0.85), 0.9(0.7 to 0.1), 1.3(1 to 1.6), 1.7(1.4 to 2), 2.1(1.7 to 2.5), 2.5(2 to 3), 3.6(2.8 to 4.4), 5(4 to 6), 6.6(5.2 to 8), 9(7 to 11), 11(9 to 13)*, 15(12 to 18)*
T21, T25	TH-T25 <sup>Note 3</sup>	0.24(0.2 to 0.32), 0.35(0.28 to 0.42), 0.5(0.4 to 0.6), 0.7(0.55 to 0.85), 0.9(0.7 to 1.1), 1.3(1 to 1.6), 1.7(1.4 to 2), 2.1(1.7 to 2.5), 2.5(2 to 3), 3.6(2.8 to 4.4), 5(4 to 6), 6.6(5.2 to 8), 9(7 to 11), 11(9 to 13), 15(12 to 18), 22(18 to 26)*
T35	TH-T25	0.24 (0.2 to 0.32), 0.35 (0.28 to 0.42), 0.5 (0.4 to 0.6), 0.7 (0.55 to 0.85), 0.9 (0.7 to 1.1), 1.3 (1 to 1.6), 1.7 (1.4 to 2), 2.1 (1.7 to 2.5), 2.5 (2 to 3), 3.6 (2.8 to 4.4), 5 (4 to 6), 6.6 (5.2 to 8), 9 (7 to 11), 11 (9 to 13), 15 (12 to 18), 22 (18 to 26)
	TH-T50	29 (24 to 34)
T50	TH-T25	0.24 (0.2 to 0.32), 0.35 (0.28 to 0.42), 0.5 (0.4 to 0.6), 0.7 (0.55 to 0.85), 0.9 (0.7 to 1.1), 1.3 (1 to 1.6), 1.7 (1.4 to 2), 2.1 (1.7 to 2.5), 2.5 (2 to 3), 3.6 (2.8 to 4.4), 5 (4 to 6), 6.6 (5.2 to 8), 9 (7 to 11), 11 (9 to 13), 15 (12 to 18), 22 (18 to 26)
	TH-T50	29 (24 to 34), 35 (30 to 40), 42 (34 to 50)
T65	TH-T65	15 (12 to 18), 22 (18 to 26), 29 (24 to 34), 35 (30 to 40), 42 (34 to 50), 54 (43 to 65)
T80	TH-T65	15 (12 to 18), 22 (18 to 26), 29 (24 to 34), 35 (30 to 40), 42 (34 to 50), 54 (43 to 65)
	TH-T100	67 (54 to 80)
T100	TH-T65	15 (12 to 18), 22 (18 to 26), 29 (24 to 34), 35 (30 to 40), 42 (34 to 50), 54 (43 to 65)
	TH-T100	67 (54 to 80), 82 (65 to 100)

Note 1: Select the value closer to the heater designation if the stabilized current has two values.

Note 2: Heater designation marked with \* has Magnetic Starters frames that cannot be applied. For information on the applicable Magnetic Starters frames, refer to the "Heater rating (designation) of standard Thermal Overload Relays" field in the above table.

Note 3: The connection conductor kit UN-TH21 is required to use in combination with the Magnetic Contactor to make a Magnetic Starters.

## Magnetic Contactors

- S-T series (non-Reversing)
- S-2xT series (Reversing)

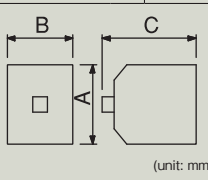
Model name	Non-Reversing		S-T10	S(D)-T12	S(D)-T20	S(D)-T21	S-T25	S(D)-T32	
	Reversing		S-2xT10	S(D)-2xT12	S(D)-2xT20	S(D)-2xT21	S-2xT25	S(D)-2xT32	
Rated operational current (A) Category AC-3 (Note 1, 2)	220 to 240VAC		11[11]	13[13]	18[18]	25[20]	30(26)[26]	32[32]	
	380 to 440VAC		9[7]	12[9]	18[18]	23[20]	30(26)[25]	32[32]	
	500VAC		7[6]	9[9]	17[17]	17[17]	24[20]	24[20]	
Conventional free air thermal current Ith (A)			20	20	20	32	32	32	
Operation coil rating			Refer to pages 22						
Auxiliary contact arrangement	Non-Reversing	Standard	1a	1a1b	1a1b	2a2b	2a2b	—	
		Special	1b	2a	2a	—	—	—	
	Reversing	Standard	1a×2+2b	1a1b×2+2b	1a1b×2+2b	2a2b×2	2a2b×2	—	
		Special	1b×2+2b	2b×2+2b	2b×2+2b	—	—	—	
 (unit: mm)	Non-Reversing	A	75	75	75	81	81	81	
		B	36	43	43	63	63	43	
		C	78	78(100)	78(100)	81(108)	81	81(108)	
	Reversing	A	85	85	85	81	81	81	
		B	82	97	97	136	136	96	
		C	78	78(100)	78(100)	81(114)	81	111(138)	
IEC 35mm rail mounting type			←—————→					→	
Option	Front clip-on auxiliary contact block mounting type		←—————→					→	
	Side clip-on auxiliary contact block mounting type		←—————→					→	
	Surge absorber mounting type		←—————→					→	

Note 1: The figure in the square brackets indicates the rated current shown on the rating plate of the product at which the category AC-3 opening/closing durability is 2,000,000 times (1,000,000 times for the T20 380V). Refer to the electric durability curve for the life performance.

Note 2: The content within ( ) of rated capacity and rated operational current is applied to the Magnetic Contactor.

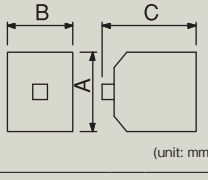
Model name	Non-Reversing		S(D)-T35	S(D)-T50	S(D)-T65	S(D)-T80	S(D)-T100
	Reversing		S(D)-2xT35	S(D)-2xT50	S(D)-2xT65	S(D)-2xT80	S(D)-2xT100
Rated operational current (A) Category AC-3 (Note 1)	220 to 240VAC		40[35]	55[50]	65[65]	85[80]	105[100]
	380 to 440VAC		40[32]	50[50]	65[65]	85[80]	105[93]
	500VAC		32[26]	38[38]	60[45]	75[75]	85[75]
Conventional free air thermal current Ith (A)			60	80	100	120	150
Operation coil rating			Refer to pages 22				
Auxiliary contact arrangement	Non-Reversing	Standard	2a2b	2a2b	2a2b	2a2b	2a2b
		Special	—	—	—	—	—
	Reversing	Standard	2a2b×2	2a2b×2	2a2b×2	2a2b×2	2a2b×2
		Special	—	—	—	—	—
 (unit: mm)	Non-Reversing	A	89		106		124(134)
		B	75		88		100
		C	91(123)		106(133)		127(157)
	Reversing	A	114		115		140(147)
		B	160		216		270
		C	97(129)		112(139)		137(167)
IEC 35mm rail mounting type			←—————→				→
Option	Front clip-on auxiliary contact block mounting type		←—————→				→
	Side clip-on auxiliary contact block mounting type		←—————→				→
	Surge absorber mounting type		←—————→				→

Note 1: The figure in the square brackets indicates the rated current shown on the rating plate of the product at which the category AC-3 opening/closing durability is 2,000,000 times (1,000,000 times for the T20 380V). Refer to the electric durability curve for the life performance.



## Thermal Overload Relays

### ● TH-T series

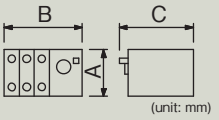
Model name	TH-T18	TH-T25	TH-T50	TH-T65	TH-T100	
Application	MSO-T10 MSOD-T12 -T12 -T20	MSO-T21 MSOD-T21 -T25 -T35 -T35 -T50	MSO-T35 MSOD-T35 -T50	MSO-T65 MSOD-T65 -T80 -T80 -T100 -T100	MSO-T80 MSOD-T80 -T100 -T100	
Standard heater rating (designation) (A)	0.12, 0.17, 0.24, 0.35, 0.5, 0.7, 0.9, 1.3, 1.7, 2.1, 2.5, 3.6, 5, 6.6, 9, 11, 15	0.24, 0.35, 0.5, 0.7, 0.9, 1.3, 1.7, 2.1, 2.5, 3.6, 5, 6.6, 9, 11, 15, 22	29, 35, 42	15, 22, 29, 35, 42, 54	67, 82	
Contact arrangement	1a1b	1a1b	1a1b	1a1b	1a1b	
 (unit: mm)	A	55	53	74	57	73.5
	B	45	63	74.3	89	89
	C	76.5	80	88	83.5	83.5

### ● Heater types

Heater types of TH type Thermal Overload Relays

Model	For Magnetic Starters		For single mounting		Heater designation (adjustable range of stabilized current) (A)													
	2-element	3-element	2-element	3-element														
Standard	T18	T18KP	— Note 1	— Note 1	0.12(0.1 to 0.16)	0.17(0.14 to 0.22)	0.24(0.2 to 0.32)	0.35(0.28 to 0.42)	0.5(0.4 to 0.6)	0.7(0.55 to 0.85)	0.9(0.7 to 1.1)	1.3(1 to 1.6)	1.7(1.4 to 2)	2.1(1.7 to 2.5)	2.5(2 to 3)	3.6(2.8 to 4.4)	5(4 to 6)	6.6(5.2 to 8)
	T25	T25KP	T25 Note 1	T25KP Note 1	0.24(0.2 to 0.32)	0.35(0.28 to 0.42)	0.5(0.4 to 0.6)	0.7(0.55 to 0.85)	0.9(0.7 to 1.1)	1.3(1 to 1.6)	1.7(1.4 to 2)	2.1(1.7 to 2.5)	2.5(2 to 3)	3.6(2.8 to 4.4)	5(4 to 6)	6.6(5.2 to 8)	9(7 to 11)	11(9 to 13)
	T50	T50KP	—	—	29(24 to 34)	35(30 to 40)	42(34 to 50)											
	T65	T65KP	T65	T65KP	15(12 to 18)	22(18 to 26)	29(24 to 34)	35(30 to 40)	42(34 to 50)	54(43 to 65)								
	T100	T100KP	—	—	67(54 to 80)	82(65 to 100)												
Quick trip type	—	T18FSKP	— Note 1	— Note 1	2.1(1.7 to 2.5)	3.6(2.8 to 4.4)	5(4 to 6)	6.6(5.2 to 8)	9(7 to 11)	11(9 to 13)	15(12 to 18)							
	T25FS	T25FSKP	T25FS	T25FSKP	2.1(1.7 to 2.5)	3.6(2.8 to 4.4)	5(4 to 6)	6.6(5.2 to 8)	9(7 to 11)	11(9 to 13)	15(12 to 18)	22(18 to 26)						
	T50FS	T50FSKP	—	—	29(24 to 34)	35(30 to 40)	42(34 to 50)											
	T65FS	T65FSKP	T65FS	T65FSKP	42(34 to 50)	54(43 to 65)												
	T100FS	T100FSKP	—	—	67(54 to 80)	82(65 to 93)												
Delay trip type	T18SR	—	— Note 1	— Note 1	0.24(0.2 to 0.32)	0.35(0.28 to 0.42)	0.5(0.4 to 0.6)	0.7(0.55 to 0.85)	0.9(0.7 to 1.1)	1.3(1 to 1.6)	1.7(1.4 to 2)	2.1(1.7 to 2.5)	2.5(2 to 3)	3.6(2.8 to 4.4)	5(4 to 6)	6.6(5.2 to 8)	9(7 to 11)	11(9 to 13)
	T25SR	T25KPSR	T25SR Note 1	T25KPSR Note 1	0.24(0.2 to 0.32)	0.35(0.28 to 0.42)	0.5(0.4 to 0.6)	0.7(0.55 to 0.85)	0.9(0.7 to 1.1)	1.3(1 to 1.6)	1.7(1.4 to 2)	2.1(1.7 to 2.5)	2.5(2 to 3)	3.6(2.8 to 4.4)	5(4 to 6)	6.6(5.2 to 8)	9(7 to 11)	11(9 to 13)
	T50SR	T50KPSR	—	—	29(24 to 34)	35(30 to 40)	42(34 to 50)											
	T65SR	T65KPSR	T65SR	T65KPSR	15(12 to 18)	22(18 to 26)	29(24 to 34)	35(30 to 40)	42(34 to 50)	54(43 to 65)								
	T100SR	T100KPSR	—	—	67(54 to 80)	82(65 to 100)												

Note 1: Combining UT-HZ18 allows the T18 frame to be used singly (screw mounting or IEC 35 mm rail mounting).  
Combining UN-RM20 allows the T25 frame for single mounting to have the IEC 35mm rail mounted.

## Contact Relays

### Specification List

Model name			SR-T5	SRD-T5	SR-T9	SRD-T9
Number of poles			5		9	
Contact arrangement			5a		9a	
			4a1b		7a2b	
			3a2b		5a4b	
Rated insulation voltage [V]			690			
Applicable standard			IEC60947-5-1,EN60947-5-1,JIS C8201-5-1,GB14048.5			
Rated impulse withstand voltage [kV]			6			
Rated frequency [Hz]			50/60			
Pollution degree			3			
Conventional free air thermal current Ith [A]			10			
Contact rating (Note 1)	AC rated operational current [A]	Category AC-15 (Coil load)	120VAC	6		
			240VAC	3		
			440VAC	1.5		
			550VAC	1.2		
	DC rated operational current [A]	Category DC-13 (large coil load)	120VAC	10		
			240VAC	8		
			440VAC	5		
			550VAC	5		
DC rated operational current [A]	Category DC-12 (resistive loads)	24VDC	3			
		48VDC	1.5			
		110VDC	0.6(2)			
		220VDC	0.3(0.8)			
DC rated operational current [A]	Category DC-12 (resistive loads)	24VDC	10			
		48VDC	8			
		110VDC	5(8)			
		220VDC	1(3)			
Minimum applicable load level			20V 3mA			
Performance	Mechanical durability [ten thousand times]		1,000			
	Electrical durability [ten thousand times]		50			
	Switching frequency [time/hour]		1,800			
Characteristic	Coil consumption (Note 3)	Inrush [VA]	45	-	45	-
		Sealed [VA]	7	-	7	-
	Power consumption (Note 3) [W]		2.2 (Note 3)	3.3(2.2) (Note 4)	2.2 (Note 3)	3.3 (Note 4)
	Time constant [mg]		-	40(45) (Note 4)	-	40(45) (Note 4)
Optional unit (Note 2)	Surge absorber unit		○		○	
	Additional auxiliary contact block		○		×	
	IEC 35mm rail mounting		○		○	

Note 1: The value in brackets indicates the current when switching the load with two poles installed in series.

Note 2: In the optional unit field, ○ and X indicate mountable and non-mountable, respectively.

Note 3: Coil consumption are average values in case of applying 220V60Hz to AC200V coil.

Note 4: Coil consumption are average values in case of DC200V coil. The value in brackets indicates average values in case of DC12V and DC24V coil.

# Contact Relays

## Contact arrangement/Contact placement

Model name	SR-T5 SRD-T5	SR-T9 SRD-T9
Contact arrangement	5a 4a1b 3a2b	9a 7a2b 5a4b
Contact placement	<p>5a</p>	<p>9a</p>
	<p>4a1b</p>	<p>7a2b</p>
	<p>3a2b</p>	<p>5a4b</p>

## Combination with additional auxiliary contact block

The SR-T series contactor type Contactor Relay is usable in combination with the following additional auxiliary contact blocks.

Auxiliary contact blocks		Front clip-on						Side clip-on	
		UT-AX4			UT-AX2			UT-AX11	UT-AX11
Model name	Contact arrangement	4a	3a1b	2a2b	2a	1a1b	2b	1a1b+1a1b	1a1b
SR-T5 SRD-T5	5a	9a	8a1b	7a2b	7a	6a1b	5a2b	7a2b	6a1b
	4a1b	8a1b	7a2b	6a3b	6a1b	5a2b	4a3b	6a3b	5a2b
	3a2b	7a2b	6a3b	5a4b	5a2b	4a3b	3a4b	5a4b	4a3b

Note 1: The auxiliary contact blocks cannot be mounted on SR(D)-T9.

Note 2: The Contactor Relay is not usable with front clip-on and side clip-on blocks mounted at the same time.

Note 3: The contact arrangements in are standard combinations.

MS-T Series Introduction

Selection and Application

Application to Thermal Overload Relays

Product Introduction

Overseas Standard

Type Codes





Order Procedure



Outline Drawing



Warranty and Safety

## Optional Units

### Model list (for MS-T series)

Model name		Auxiliary contact blocks			Operation coil surge absorber unit				
Type		UT-AX4	UT-AX2	UT-AX11	UT-SA21	UT-SA22	UT-SA13	UT-SA23	UT-SA25
Mounting		Front clip-on		Side clip-on	Mounting on top				
Specification/ Function		Twin contact built-in 4-pole auxiliary contact (4a, 2a2b, 3a1b)	Twin contact built-in 2-pole auxiliary contact (2a, 1a1b, 2b)	Twin contact built-in 2-pole auxiliary contact (1a1b)	Operation coil surge absorber				
					With varistor 24VAC (Shared with DC) 48VAC (Shared with DC) 200VAC (Shared with DC) 400VAC	With varistor + indicating LED 200VAC (Shared with DC)	With CR DC200V	With CR AC200V	With varistor + CR 48VAC (Shared with DC) 200VAC (Shared with DC)
Appearance (Typical example)									
		UT-AX4	UT-AX2	UT-AX11	UT-SA21				
Applied model	Magnetic Starters	S-T10~T50/SD-T12~T50							
	Magnetic Contactors	MSO-T10~T25/MSOD-T12~T21							
	Contact Relays	SR(D)-T5			SR(D)-T5/T9				
	thermal relay	-							

Model name		Mechanical interlocks		Single mounted unit	Main circuit conductor kit		
Type		UT-ML11	UT-ML20	UT-HZ18	UT-SD10	UT-SD20	UT-SD25
Mounting		Side clip-on		-	-		
Specification/ Function		Combining it with two single Magnetic Contactors configures the reversing type. ML11 is the electrical interlock 2b contact built-in type.		When used in combination with the thermal relay, screw mounting and mounting on the IEC35mm rail are possible.	Conductor unit used for reversible connection *6 conductors/set (Note 2) (Note 3)		
Appearance (Typical example)							
		UT-ML11		UT-HZ18	UT-SD10		
Applied model	Magnetic Starters	ST10~T20	SD-T12~T20		S-T10	S(D)-T12/T20	S(D)-T21/T25
	Magnetic Contactors	-	-	-	-	-	-
	Contact Relays	-			-		
	thermal relay	-		TH-T18(KP)	-		

Model name		DC/AC interface unit for coil		Main circuit surge absorber unit	
Type		UT-SY21	UT-SY22	UT-SA3320	UT-SA3332
Mounting		Mounting on top		Mounting on head	
Specification/Function		No-contact output (Triac output)	Contact output (Relay output)	C+R delta connection	
Appearance (Typical example)					
		UT-SY21		UT-SA3320	
Applied model	Magnetic Starters	S-T10~T50		S(D)-T10~T20	S(D)-T21~T32
	Magnetic Contactors	MSO-T10~T50		MSO(D)-T10~T20	MSO(D)-T21~T32
	Contact Relays	-		-	-
	thermal relay	-		-	-

Note 1: The head on and side on type mounting styles cannot be used simultaneously on the auxiliary contact unit.

Note 2: Power supply side and load side conductors are available, and therefore care should be taken when connecting.

Note 3: Use UN-SD18CX when mounting on T32.

## ● UT-AX□ auxiliary contact block

### Ratings and specifications

Model name			UT-AX4	UT-AX2	UT-AX11
Mounting method			Front clip-on	Front clip-on	Side clip-on
Number of poles			4	2	2
Contact arrangement			4a	2a	1a1b
			3a1b	1a1b	
			2a2b	2b	
Applicable model	Magnetic Contactor	AC operated type	S-T10, T12, T20, T21, T25, T32, T35, T50		
		DC operated type	S-DT12, T20, T21, T32, T35, T50		
	Contactor Relay	AC operated type	SR-T5		
		DC operated type	SRD-T5		
Rated insulation voltage [V]			690		
Rated impulse withstand voltage [kV]			6		
Rated frequency [Hz]			50/60		
Pollution degree			3		
Conventional free air thermal current I <sub>th</sub> [A]			10		
Contact rating (Note 2)	AC rated operational current [A]	Category AC-15 (coil load)	AC120V	6	
			AC240V	3	
			AC440V	1.5	
			AC550V	1.2	
	DC rated operational current [A]	Category AC-12 (resistive load)	AC120V	10	
			AC240V	8	
			AC440V	5	
			AC550V	5	
DC rated operational current [A]	Category DC-13 (large coil load)	DC24V	3		
		DC48V	1.5		
		DC110V	0.6(2)		
		DC220V	0.3(0.8)		
DC rated operational current [A]	Category DC-12 (resistive load)	DC24V	10		
		DC48V	8		
		DC110V	5(8)		
		DC220V	1(3)		
Minimum applicable load level			5V 3mA		20V 3mA
Performance	Mechanical durability [ten thousand times]		1,000		
	Electrical durability [ten thousand times]		50		
	Switching frequency [time/hour]		1,800		
	Terminal screw size/type		M3.5 cross slot screw with pressure plate		
Applicable electric wire size [φmm,mm <sup>2</sup> ]		φ1.6 0.75 to 2.5			
Applicable crimp lug size		1.25-3.5 to 2-3.5			
Terminal screw tightening torque [N·m]		0.9 to 1.5			

Note 1: It is not possible to mount both the front clip-on and side clip-on units at the same time.

Note 2: The value in brackets indicates the current when switching the load with two poles installed in series.



## ● UT-ML□ Mechanical Interlock Unit

### Application

Model	Applicable Magnetic Contactor model
UT-ML11	S-T10, T12, T20
UT-ML20	SD-T12, T20
UN-ML21 (Note1)	S-T21, T25, T32, T35, T50, T65, T80 SD-T21, T32, T35, T50, T65, T80
UN-ML80	S-T100, SD-T100

Note 1: Use UN-ML21 of the MS-N Series as the mechanical interlock unit for S-T21 to T32.

### Specifications

Model	UT-ML11
Rated insulation voltage	690V
Rated impulse withstand voltage	6kV
Rated frequency	50/60Hz
Pollution degree	3
Terminal screw size/type	M3.5 cross slot screw with pressure plate
Applicable electric wire size[φmm,mm <sup>2</sup> ]	φ1.6 0.75 to 2.5
Applicable crimp lug size	1.25-3.5 to 2-3.5
Terminal screw tightening torque[N·m]	0.9 to 1.5

### Mounting

#### Hole drilling dimension

(Drilling of holes is not required when mounting the IEC 35mm rail mountable model is mounted to the IEC 35mm rail for reversing.)

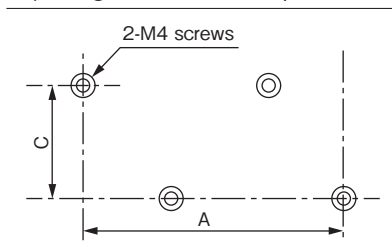

Model	Applicable frame	Dimension[mm]		
		A±0.2	B±0.2	C±0.3
UT-ML11	T10	74	—	60
	S-T12, T20	89	—	60
UT-ML20	SD-T12, T20	89	—	60

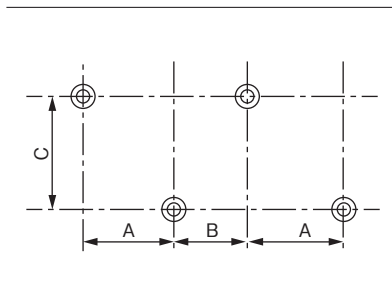

Model	Applicable frame	Dimension[mm]		
		A±0.2	B±0.2	C±0.3
UN-ML21	T21, T25	54(54)	19(19)	60(56)
	T35, T50	65	20	70
	T65, T80	70	28	75
	S-T32	30	23	60
	SD-T32	32	21	67
UN-ML80	S-T100	80	57	80
	SD-T100	80	57	80

## ● UT-HZ18 (BC) Independent mounting unit for thermal relay

### Type and applicable model

Model	Mounting	Applicable model
UT-HZ18	Screw mounting	TH-T18(KP)
UT-HZ18BC	IEC 35mm rail mounting	TH-T18BC(KP)
UN-RM20	IEC 35mm rail mounting	TH-T25(BC)(KP), TH-T25(BC)(KP)SR

Note 1: □BC is the model with wiring streamlining terminal.

## ● UT-SD□ Main Circuit Conductor Kit

### Types and Application

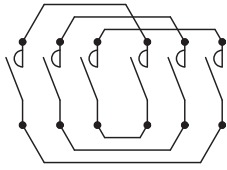
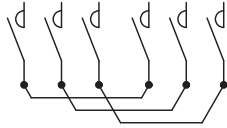
Applicable magnetic contactor frame	Reversible type	Crossover type
		
T10	UT-SD10	UT-SG10
T12, T20	UT-SD20	UT-SG20
T21, T25	UT-SD25	UT-SG25
Remarks	The kit contains six conductors per set. Power supply side and load side conductors are available, and therefore care should be taken when connecting.	The kit contains three conductors per set. The conductors can also be connected to the power supply terminal.

## ● UT-SA33□ Main Circuit Surge Absorber Unit

### Types

Model	Mounting method	Internal element specifications	Rated voltage/frequency	Applicable model
UT-SA3320	Mounting on head	$(0.3\mu F + 60\Omega) \times 3$	AC240V 50/60Hz	S-T10, T12, T20 (BC) SD-T12, T20 (BC)
UT-SA3332				S-T21, T25, T32 (BC) SD-T21, T32 (BC)
UN-SA33	Independent mounting	$(0.5\mu F + 50\Omega) \times 3$		S-T10(BC)~T100 SD-T12(BC)~T100

### Specifications

Withstand voltage		Insulation resistance	Superimposed pulse conditions (maximum)		Maximum applied voltage	Mechanical resistance (Type mounted on head)
Across terminals	Across terminal and case		Peak value	Pulse width		
600VAC for one minute	2000VAC for one minute	300M $\Omega$ or more	2000V	1 $\mu$ sec.	800V	Ten million times

#### Notes for use

- (1) Do not use this unit in a circuit with high frequency elements, such as an inverter circuit.
- (2) Do not use this unit on the load side of a device with low contact capacity, such as a relay.

### Connection

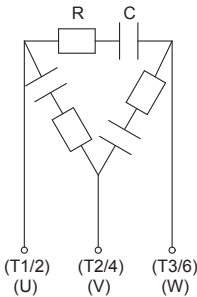
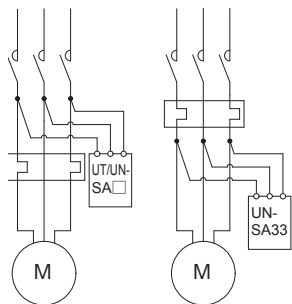
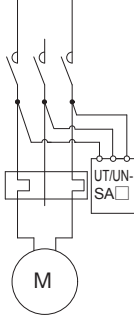
Internal connection	Connection example	
	3-phase circuit	Single-phase circuit
		



## ● UT/UN-SY□ DC/AC Interface Unit for Operation Coils

### Model

Unit model	Output method	Unit mounting method	Applicable magnetic contactor, magnetic relay model
UT-SY21	No-contact output (Triac output)	Additional mounting on top	S-T10~T50
UT-SY21BC			
UT-SY22	Contact output (Relay output)	Independent mounting	S-T10~T100
UT-SY22BC			
UN-SY11	No-contact output (Triac output)	Independent mounting	S-T10~T100
UN-SY12	Contact output (Relay output)		
UN-SY31	No-contact output (Triac output)	Additional mounting on top	S-T65, T80
UN-SY32	Contact output (Relay output)		

Note 1. A coil voltage nominal of 100VAC, 100V or 200VAC can be applied for the operation coil.

### Specifications

Model		UT-SY21	UT-SY22	UN-SY11	UN-SY31	UN-SY12	UN-SY32
Input section	Rated working voltage	DC24V					
	Tolerable voltage fluctuation	85% to 110% of rated working voltage					
	Current	15mA	10mA	15mA		10mA	
	Power consumption	0.4W	0.24W	0.4W		0.24W	
	Minimum operation voltage	18V					
Output section	Maximum opening voltage	4V	1V	4V		1V	
	Output specifications	No-contact output(Triac output)	Contact output	No-contact output(Triac output)		Contact output	
	Rated working voltage	AC100V~AC240V 50/60Hz					
	Output current	0.5A AC-15					
	Leakage current when open	5mA/240V	None	5mA/240V		None	
	Operating time	1ms when operating, 0.5 cycle +1ms or less when open	10ms or less	1ms when operating, 0.5 cycle +1ms or less when open		10ms or less	
	Switching durability	Mechanical	—	5,000,000 times	—		5,000,000 times
Electrical		—	5,000,000 times	—		1,000,000 times (Note 1)	1,000,000 times
Working temperature		-10°C~55°C					
Applicable terminal wire	Wire	φ1.6mm, 1.25~2mm <sup>2</sup>					
	Crimp minial	1.25-3.5, 2-3.5					
	Tightening torque	0.9~1.5N·m		0.9~1.5N·m			

Note 1: 5,000,000 times when using UN-SY12 and SR-K100 types in combination.

### Connection example (Connection diagram)

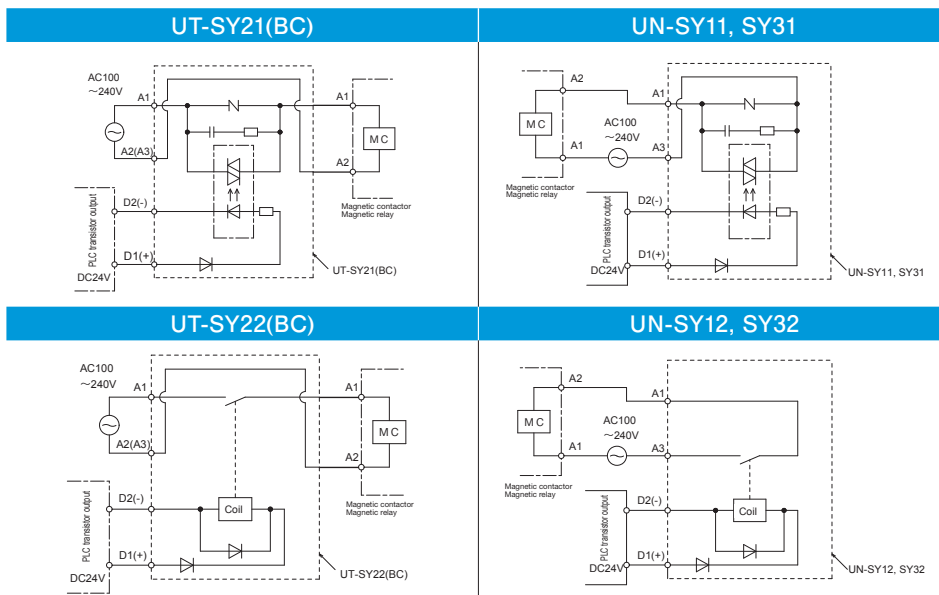

## We support your overseas business.



■ Our standard products comply with the domestic standards as well as various overseas standards and are certified to meet all the standards. (Note1)

Type	Model name	Applicable standard					Safety certification standard
		International	Japan	European countries	China	U.S. & Canada	
		IEC	JIS	EN EC directive CE	Certificate authority TÜV Rheinland	GB CCC	cULUS LISTED
Magnetic Contactors	S(D)-T10 to T100	⊙	⊙	⊙	⊙	⊙	⊙
Thermal Overload Relays	TH-T18KP to T100KP	⊙	⊙	⊙	⊙	⊙	⊙
Open Type Magnetic Starters	MSO(D)-T10KP to T100KP (Note2)	○	○	○	○	⊙	○
Enclosed Magnetic Starters	T10KP to T100KP	○	○	—	—	—	—
Contactor Relays	SR(D)-T5/T9	⊙	⊙	⊙	⊙	⊙	⊙

Note1: ○:Compliant or supported with standard parts, ⊙:Certified with standard parts

Note2: The Magnetic Starters will be certified under each type name of the Magnetic Contactors and the Thermal Overload Relays on the condition that the Magnetic Contactors and the Thermal Overload Relays are used in combination.

## UL Standards Certified product

### ■ AC Operating Magnetic Contactor (Non-Reversing) T Series

 (File No. E58968)

Model		Rated capacity [HP]						Rated energizing current [A]	Remarks
Magnetic contactors	Applicable	Single-phase(only nonreversible type)		3-phase					
		110 ~ 120V	220 ~ 240V	200V	220 ~ 240V	440 ~ 480V	550 ~ 600V		
S-T10(BC)(SA)	○	1/2	1 1/2	3	3	5	5	13	The standard product is certified with  .
S-T12(BC)(SA)	○	1/2	1 1/2	3	3	7 1/2	7 1/2	20	
S-T20(BC)(SA)	○	1	2	3	5	7 1/2	7 1/2	20	
S-T21(BC)(SA)	○	1	3	5	5	10	10	30	
S-T25(BC)(SA)	○	2	3	7 1/2	7 1/2	15	15	30	
S-T32(BC)(SA)	○	2	5	10	10	20	15	32.5	
S-T35(BC)(SA)	○	2	5	10	10	20	20	40	
S-T50(BC)(SA)	○	3	7 1/2	15	15	30	30	65	
S-T65	○	3	10	15	20	40	40	95	
S-T80	○	5	10	20	25	50	50	100	
S-T100	○	7 1/2	15	25	30	60	60	100	

### ■ AC Operating Magnetic Contactor (Reversing) T Series

 (File No. E58968)

Model		Rated capacity [HP]				Rated energizing current [A]	Remarks
Magnetic contactors	Applicable	3-phase					
		200V	220 ~ 240V	440 ~ 480V	550 ~ 600V		
S-2×T10(BC)(SA)	○	3	3	5	5	13	The standard product is certified with  .
S-2×T12(BC)(SA)	○	3	3	7 1/2	7 1/2	20	
S-2×T20(BC)(SA)	○	3	5	7 1/2	7 1/2	20	
S-2×T21(BC)(SA)	○	5	5	10	10	30	
S-2×T25(BC)(SA)	○	7 1/2	7 1/2	15	15	30	
S-2×T32(BC)(SA)	○	10	10	20	15	32.5	
S-2×T35(BC)(SA)	○	10	10	20	20	40	
S-2×T50(BC)(SA)	○	15	15	30	30	65	
S-2×T65	○	15	20	40	40	95	
S-2×T80	○	20	25	50	50	100	
S-2×T100	○	25	30	60	60	100	

### ■ DC Operating Magnetic Contactor (Non-Reversing / Reversing) T Series

 (File No. E58968)

Model				Rated capacity [HP]						Rated energizing current [A]	Remarks
Non-Reversing	Applicable	Reversing	Applicable	Single-phase(only nonreversible type)		3-phase					
				110 ~ 120V	220 ~ 240V	200V	220 ~ 240V	440 ~ 480V	550 ~ 600V		
SD-T12(BC)(SA)	○	SD-2×T12(BC)(SA)	○	1/2	1 1/2	3	3	7 1/2	7 1/2	20	The standard product is certified with  .
SD-T20(BC)(SA)	○	SD-2×T20(BC)(SA)	○	1	2	3	5	7 1/2	7 1/2	20	
SD-T21(BC)(SA)	○	SD-2×T21(BC)(SA)	○	1	3	5	5	10	10	30	
SD-T32(BC)(SA)	○	SD-2×T32(BC)(SA)	○	2	5	10	10	20	15	32.5	
SD-T35(BC)(SA)	○	SD-2×T35(BC)(SA)	○	2	5	10	10	20	20	40	
SD-T50(BC)(SA)	○	SD-2×T50(BC)(SA)	○	3	7 1/2	15	15	30	30	65	
SD-T65	○	SD-2×T65	○	3	10	15	20	40	40	95	
SD-T80	○	SD-2×T80	○	5	10	20	25	50	50	100	
SD-T100	○	SD-2×T100	○	7 1/2	15	25	30	60	60	100	

Note 1: Application ... ○: Standard product

Note 2: 125A - 400A frames with "UL" at the end of the model name are  certified for solderless terminal structure.

### ■ Mechanical Latch Type Magnetic Contactor T Series

 (File No. E58968)

Model				Rated capacity [HP]						Rated energizing current [A]	Remarks
Non-Reversing	Applicable	Reversing	Applicable	Single-phase(only nonreversible type)		3-phase					
				110 ~ 120V	220 ~ 240V	200V	220 ~ 240V	440 ~ 480V	550 ~ 600V		
SL(D)-T21UL(BC)(SA)	☆	SL(D)-(2×)T21UL(BC)(SA) SL(D)-(2×)T35/T50UL(BC)(SA) SL(D)-(2×)T65/T80UL(BC)(SA) SL(D)-(2×)T100UL(BC)(SA)	☆	1	3	5	5	10	10	30	The standard product is certified with  .

Note 1: Application ... ☆ Dedicated part

## Thermal Overload Relays T Series





 (File No. E58968)

Model	Applicable	Heater Designation [Adjustment Range (RC Value) (A) of Settling Current]	Auxiliary contact	
			Rated Code	Making Breaking
TH-T18KP	○	0.12A(0.1~0.16), 0.17(0.14~0.22), 0.24A(0.2~0.32), 0.35A(0.28~0.42), 0.5A(0.4~0.6), 0.7A(0.55~0.85), 0.9A(0.7~1.1), 1.3A(1~1.6), 1.7A(1.4~2), 2.1A(1.7~2.5), 2.5A(2~3), 3.6A(2.8~4.4), 5A(4~6), 6.6A(5.2~8), 9A(7~11), 11A(9~13), 15A(12~18)*1	C600 AC600Vmax	1800VA(15A max) 180VA(1.5A max)
TH-T25KP	○	0.24A(0.2~0.32), 0.35A(0.28~0.42), 0.5A(0.4~0.6), 0.7A(0.55~0.85), 0.9A(0.7~1.1), 1.3A(1~1.6), 1.7A(1.4~2), 2.1A(1.7~2.5), 2.5A(2~3), 3.6A(2.8~4.4), 5A(4~6), 6.6A(5.2~8), 9A(7~11), 11A(9~13), 15A(12~18), 22A(18~26)		
TH-T50KP	○	29A(24~34), 35A(30~40), 42A(34~50)	B600 AC600Vmax	
TH-T65KP	○	15A(12~18), 22A(18~26), 29A(24~34), 35A(30~40), 42A(34~50), 54A(43~65)		3600VA(30A max) 360VA(3A max)
TH-T100KP	○	67A(54~80), 82A(65~100)		

\*1. The available current rating is 16A or less.

## Contactor Relays T Series

 (File No. E58968)

Model		Rated			Remarks
AC operating	DC operating	A600	Q300	R300	
 SR-T5(BC)(SA)	 SRD-T5(BC)(SA)	AC600V max Making 7200VA Breaking 720VA	DC250V max	DC250V max Making 69VA Breaking 69VA	The standard product is certified with  .
 SR-T5(BC)(SA)	 SRD-T9(BC)(SA)				

## Optional Units T Series (File No. E58969)

Model	
UT-AX2(BC),AX4(BC),AX11(BC)	◎
UT-ML11(BC),ML20(BC)	①
UT-SA21,SA23,SA25	◎

Note1.◎:Standard Product and Displayed on the Product.

①:Certified as a contactor component.(mark not displayed on the product)

## ■ Applicable wire size, lug size and tightening torque

Model	S-T10/S(D)T12/T20			S(D)-T21	S-T25	S(D)-T21/T25	S-T21/T25	S(D)-T32	
	Main	Auxiliary	Control	Main		Auxiliary	Control	Main	Control
Terminal	M3.5	M3.5	M3.5	M4		M3.5	M3.5	M4	M3.5
Screw size									
Wire strip length	10mm	10mm	9mm	11.5mm		11.5mm	9mm	11.5mm	9mm
Wire size (60/75°C) (copper only) (Sol./Str.)	14 - 12 AWG	14 AWG	14 AWG	14 - 10 AWG	14 - 8 AWG	14 AWG	14 AWG	14 - 10 AWG 8 AWG *1	14 AWG
Recommended Crimp Lug Size (JST Cat No.) *2	1.25-3.5~2-3.5 5.5-S3	1.25-3.5~2-3.5	1.25-3.5~2-3.5	1.25-4~5.5-4	1.25-4~5.5-4 8-4NS	1.25-3.5~ 2-3.5	1.25-3.5~ 2-3.5	1.25-4~5.5-4 8-4NS	1.25-3.5~2-3.5
Connection to terminal Max. qty.	2 Wires or 2 Lugs per terminal *3								
Tightening torque	10.3 lb-in (1.17N·m)	10.3 lb-in (1.17N·m)	10.3 lb-in (1.17N·m)	15 lb-in (1.69N·m)		10.3 lb-in (1.17N·m)	10.3 lb-in (1.17N·m)	15 lb-in (1.69N·m)	10.3 lb-in (1.17N·m)

\*1. When using 8AWG with a 3-phase AC200 to 208V, use a copper wire with wire temperature rating of 75°C.

\*2. Please use swaging tool which is recommended by JST.

\*3. Two conductors of the same size can be connected.

Model	S(D)-T35/T50			S(D)-T65	S(D)-T80	S(D)-T65/T80		S(D)-T100		
	Main	Auxiliary	Control	Main	Auxiliary	Control	Main	Auxiliary	Control	
Terminal	M5	M3.5	M3.5	M6		M4	M4	M6	M4	M4
Screw size										
Wire strip length	15mm	11.5mm	9mm	—		11mm	11mm	—	11mm	11mm
Wire size (60/75°C) (copper only) (Sol./Str.)	14-6 AWG *1	14 AWG	14 AWG	14-2 AWG	14-1 AWG *2	14 AWG	14 AWG	14-1/0 AWG *3	14 AWG	14 AWG
Recommended Crimp Lug Size (JST Cat No.)	1.25-5~14-5	1.25-3.5~2-3.5	1.25-3.5~2-3.5	1.25-6~22-6	1.25-6~22-6 38-S6	1.25-4~2-4	1.25-4~2-4	1.25-6~22-6 38-S6, 60-6	1.25-4~2-4	1.25-4~2-4
Connection to terminal Max. qty.	2 Wires or 2 Lugs per terminal *4									
Tightening torque	22.5 lb-in (2.54N·m)	10.3 lb-in (1.17N·m)	10.3 lb-in (1.17N·m)	39.1 lb-in (4.41N·m)		15 lb-in (1.69N·m)	15 lb-in (1.69N·m)	39.1 lb-in (4.41N·m)	15 lb-in (1.69N·m)	15 lb-in (1.69N·m)

\*1. When using 6AWG, use a copper wire with wire temperature rating of 75°C.

\*2. When using 1AWG, use a copper wire with wire temperature rating of 75°C.

\*3. When using 1/0AWG, use a copper wire with wire temperature rating of 75°C.

\*4. Two conductors of the same size can be connected.

Model	TH-T18KP		TH-T25KP		TH-T50KP		TH-T65KP		TH-T100KP		SR(D)-T5/T9	
	Main	Auxiliary	Main	Auxiliary	Main	Auxiliary	Main	Auxiliary	Main	Auxiliary	Auxiliary	Main
Terminal	M3.5	M3.5	M4	M3.5	M5	M3.5	M6	M4	M6	M4	M3.5	M3.5
Screw size												
Wire strip length	10.5mm	10.5mm	10mm	10.5mm	13.5mm	10.5mm	—	11mm	—	11mm	10mm	9mm
Wire size (60/75°C) (copper only) (Sol./Str.)	14 - 12 AWG *1	14 AWG	14 - 8 AWG	14 AWG	14-6 AWG *2	14 AWG	14-3 AWG	14 AWG	14-1 AWG *3	14 AWG	14 AWG	14 AWG
Recommended Crimp Lug Size (JST Cat No.) *4	1.25-3.5~ 2-3.5 5.5-S3	1.25-3.5~ 2-3.5	1.25-4~5.5-4 8-NK4	1.25-3.5~ 2-3.5	1.25-5~14-6	1.25-3.5~2-3.5	2-6~22-6	1.25-4~2-4	2-6~22-6	1.25-4~2-4	1.25-3.5~ 2-3.5	1.25-3.5~ 2-3.5
Connection to terminal Max. qty.	2 Wires or 2 Lugs per terminal *5				2 Wires or 2 Lugs per terminal					2 Wires or 2 Lugs per terminal *5		
Tightening torque	10.3 lb-in (1.17N·m)	10.3 lb-in (1.17N·m)	15 lb-in (1.69N·m)	10.3 lb-in (1.17N·m)	22.5 lb-in (2.54N·m)	10.3 lb-in (1.17N·m)	39.1 lb-in (4.41N·m)	15 lb-in (1.69N·m)	39.1 lb-in (4.41N·m)	15 lb-in (1.69N·m)	10.3 lb-in (1.17N·m)	10.3 lb-in (1.17N·m)

\*1. The applicable current for the heater nominal 15A is 16A or less.

\*2. When using 6AWG, use a copper wire with wire temperature rating of 75°C.

\*3. Use a copper wire with wire temperature rating of 75°C.

\*4. Please use swaging tool which is recommended by JST.

\*5. Two conductors of the same size can be connected.

## US Export Control Panel SCCR

### 1. SCCR

Initials for the Short Circuit Current Rating, it refers to the magnitude of the short-circuit current that the device or equipment can withstand.

### 2. Short-Circuit Performance of Control Panels and SCCR

#### (1) Short-Circuit Performance of Control Panels

On the name plate of a control panel, the value that represents the short-circuit performance of the control panel is given along with the manufacturer's name, rated voltage, number of phases, frequency, full load current, etc. When using the control panel, the estimated short-circuit current at the panel entry must be smaller than the short-circuit performance displayed on the name plate.

#### (2) Control Panel SCCR

Conventionally, the breaking capacity of overcurrent protection devices such as circuit breakers and fuses to be installed on the inlet port has been used as the short circuit performance of control panels (Figure 1 a) reference). However, due to the revision of the NEC (National Electric Code: the US equivalent of electrical equipment standards) in 2005, SCCR is now displayed as the short circuit performance of control panels rather than the breaking capacity of overcurrent protection devices of the inlet port.

Typically, some sort of "coordination" between devices ("protection coordination" when including a protection device) is required when constructing an electrical system by combining several electrical devices. When considering the coordination of the entire control panel and especially during a short circuit, exactly what indicators are appropriate? Can the breaking capacity of the overcurrent protection device on the inlet port explain the short circuit coordination of the control panel? One of the solutions to such questions is SCCR.

### 3. Method of Determining SCCR

#### (1) Method of Determining SCCR

The method of determining SCCR is defined in Section 409 of NEC, but SCCR is commonly determined using the UL508A Supplement SB.

#### (2) UL508A SB

UL508A SB regulates the next steps.

- ◆ Determine SCCR for individual power circuit components.
- ◆ Correct SCCR for each current-limiting element.
- ◆ Determine SCCR for the entire control panel.

Details for each are described below.

#### (1) Determine SCCR for power circuit components.

Power circuit refers to circuits of motors, heaters, lighting, etc. Power transformers, reactors, CTs and the like are not included.

SCCR of individual components is determined by one of the following methods.

- Values displayed in rating plates, instruction manuals, etc.
- Default values in SB Table 4.1

\* For example, Circuit Breaker: 5 kA, Magnetic Starter (for motors with 50 hp or less): 5 kA, etc.

- For load controllers, motor overload relays and combination motor controllers, the values verified in the performance requirements in accordance with the provisions of UL60947-4-1A or UL508, and mentioned in the procedure of the manufacturer

#### (2) Correction for Transformer Capacity and Secondary Side SCCR

For SCCR of target circuits of the following cases, this is SCCR of devices on the transformer primary side.

- a) In cases where the short-circuit current ratings and breaking ratings of all components of the secondary side are larger than the calculated value of the short-circuit current directly below the power transformer secondary side. For impedance, use either what is known or calculate by assuming that the impedance is 2.1 %.
- b) In cases where the short-circuit current ratings and breaking ratings of all components of the secondary side are larger than the values on the table as specified in UL 508A SB
- c) If it does not correspond to a / b above, the smallest SCCR of the transformer secondary side will be SCCR of the transformer primary side.

#### (3) Correction for Current Limiting Circuit Breaker and Current Limiting Fuse

When the feeder circuit has a current-limiting circuit breaker or current-limiting fuse, SCCR will be one of the following depending on the conditions of the branch circuit.

- a) If SCCR of all components of the branch circuit is equal to or greater than the passing current peak value  $I_p$  of the current-limiting circuit breaker or current-limiting fuse and SCCR of the branch circuit protection devices is equal to or greater than SCCR of the current-limiting circuit breaker or current-limiting fuse, SCCR of the current-limiting circuit breaker or current-limiting fuse of the feeder circuit will be SCCR of the branch circuit.
- b) If SCCR of all components of the branch circuit is equal to or greater than the passing current peak value  $I_p$  of the current-limiting circuit breaker or current-limiting fuse and SCCR of the branch circuit protection devices is less than SCCR of the current-limiting circuit breaker or current-limiting fuse, the smallest SCCR of the branch circuit protection device will be SCCR of the branch circuit.
- c) In conditions other than a / b above, the smallest SCCR of all components of the branch circuit will be SCCR of the branch circuit.

## Short-circuit Current Rating for Magnetic Contactor and Thermal Relay (SCCR)

■ Short-Circuit Current Rating (SCCR) of Thermal Overload Relays By using with a fuse or circuit breaker that satisfies the rated current and rated breaking current shown in the table below, the short-circuit current rating (SCCR) in the table below can be applied to thermal overload relays.

Magnetic contactors Model	Main circuit voltage:600VAC maximum		Main circuit voltage:240VAC maximum				Main circuit voltage:480VAC maximum				
	Short Circuit Current Rating (SCCR)	Maximum Rated Current of Fuse (Class K5)	Short Circuit Current Rating (SCCR)	circuit breakers			Short Circuit Current Rating (SCCR)	circuit breakers			
				Maximum Rated Current	Minimum Breaking Current	Recommended Model Name (Note 1)		Maximum Rated	Minimum Breaking Current	Recommended Model Name (Note 1)	
S-(2×)T10 S(D)-(2×)T12	5kA	30A	10kA	30A	10kA	NF50-SMU, NF50-SVFU, NV50-SVFU	10kA	30A	18kA	NF100-HRU, NV100-HRU, NF125-SVU, NV125-SVU	
25kA			35kA		NF100-SRU, NV100-SRU						
14kA			15A	25kA	NF50-SVFU, NV50-SVFU	15A		10kA			
10kA			50A	10kA	NF50-SMU, NF50-SVFU, NV50-SVFU	30A		18kA			
25kA				35kA	NF100-SRU, NV100-SRU						
14kA				15A	25kA				NF50-SVFU, NV50-SVFU		
S(D)-(2×)T20		70A	10kA	50A	10kA	NF50-SMU, NF50-SVFU, NV50-SVFU	35kA	50A	50kA	NF125-HVU, NV125-HVU	
SD-(2×)T20			25kA		35kA	NF100-HRU, NV100-HRU, NF125-SVU, NV125-SVU					
S(D)-(2×)T21			14kA	40A	14kA	NF50-SVFU, NV50-SVFU		75A	50kA		
SD-(2×)T21			10kA	50A	10kA	NF50-SMU, NF50-SVFU, NV50-SVFU					
S-(2×)T25			35kA		75A	50kA		NF100-HRU, NV100-HRU, NF125-SVU, NV125-SVU	35kA		50kA
S(D)-(2×)T32			10kA	14kA		NF100-CVFU, NV100-CVFU					
		35kA	50kA	NF100-HRU, NV100-HRU, NF125-SVU, NV125-SVU							
S(D)-(2×)T35		200A	125A	10kA	50A	10kA	NF50-SMU, NF50-SVFU, NV50-SVFU	18kA	75A	NF100-HRU, NV100-HRU, NF125-SVU, NV125-SVU	
				14kA	40A	14kA	NF50-SVFU, NV50-SVFU				
				18kA	75A	18kA	NF100-SRU, NV100-SRU, NF100-HRU, NV100-HRU				
				25kA		35kA	NF100-SRU, NV100-SRU, NF100-HRU, NV100-HRU				
			35kA	50kA	NF100-SRU, NV100-SRU, NF100-HRU, NV100-HRU, NF125-SVU, NV125-SVU	35kA	50kA	NF125-HVU, NV125-HVU			
			10kA	50A	10kA				NF50-SMU, NF50-SVFU, NV50-SVFU		
			14kA	75A	14kA	NF50-SVFU, NV50-SVFU	100A	18kA	NF100-HRU, NV100-HRU, NF125-SVU, NV125-SVU		
			18kA	100A	18kA	NF100-SRU, NV100-SRU, NF100-HRU, NV100-HRU					
			25kA		35kA	NF100-SRU, NV100-SRU, NF100-HRU, NV100-HRU					
			35kA	50kA	NF100-SRU, NV100-SRU, NF100-HRU, NV100-HRU, NF125-SVU, NV125-SVU						
S(D)-(2×)T65			300A	250A	14kA	75A	14kA	NF50-SVFU, NV50-SVFU	18kA	100A	18kA
	18kA				100A	18kA	NF100-SRU, NV100-SRU, NF100-HRU, NV100-HRU				
	25kA	225A			35kA	NF250-SVU, SV250-SVU					
	14kA	75A		14kA	NF50-SVFU, NV50-SVFU	25kA	225A	35kA	NF250-SVU, NV250-SVU		
	18kA	100A		18kA	NF100-SRU, NV100-SRU, NF100-HRU, NV100-HRU						
	25kA	225A		35kA	NF250-SVU, NV250-SVU						
S(D)-(2×)T80	10kA	225A	18kA	100A	18kA	NF100-SRU, NV100-SRU, NF100-HRU, NV100-HRU	18kA	100A	18kA	NF100-HRU, NV100-HRU, NF125-SVU, NV125-SVU	
			25kA	225A	35kA	NF250-SVU, NV250-SVU					
S(D)-(2×)T100	10kA	225A	18kA	100A	18kA	NF100-SRU, NV100-SRU, NF100-HRU, NV100-HRU	18kA	100A	18kA	NF100-HRU, NV100-HRU, NF125-SVU, NV125-SVU	
			25kA	225A	35kA	NF250-SVU, NV250-SVU					

Note 1: Examples of the recommended low-voltage breakers are given. Use a UL489-listed low-voltage breaker (3-pole part) that satisfies the ratings given above.

# Overseas Standard

Thermal Overload Relays Model	Main circuit voltage:600VAC maximum			Main circuit voltage:240VAC maximum			Main circuit voltage:480VAC maximum																
	Heater nominal	Short Circuit Current Rating (SCCR)	Maximum Rated Current of Fuse (Class K5)	Short Circuit Current Rating (SCCR)	circuit breakers			Short Circuit Current Rating (SCCR)	circuit breakers														
					Maximum Rated	Minimum Breaking Current	Recommended Model Name (Note 1)		Maximum Rated	Minimum Breaking Current	Recommended Model Name (Note 1)												
TH-T18KP	0.12A	5kA	15A	10kA / 25kA	15A	10kA / 25kA	NF50-SMU NF50-SVFU, NV50-SVFU / NF100-SRU, NV100-SRU	10kA	15A	10kA	NF100-HRU NV100-HRU  NF125-SVU NV125-SVU												
	0.17A																						
	0.24A																						
	0.35A																						
	0.5A																						
	0.7A																						
	0.9A																						
	1.3A																						
	1.7A																						
	2.1A																						
	2.5A																						
	3.6A																						
	5A																						
	6.6A																						
9A																							
11A																							
15A																							
TH-T25KP	0.24A	5kA	15A	10kA / 35kA	15A	10kA / 50kA	NF50-SMU NF50-SVFU, NV50-SVFU / NF100-HRU, NV100-HRU NF125-SVU, NV125-SVU	35kA	15A	50kA	NF125-HVU NV125-HVU												
	0.35A																						
	0.5A																						
	0.7A																						
	0.9A																						
	1.3A																						
	1.7A																						
	2.1A																						
	2.5A																						
	3.6A																						
	5A																						
	6.6A																						
	9A																						
	11A																						
15A																							
22A																							
TH-T50KP	29A	5kA	125A	10kA / 35kA	10kA	10kA	NF50-SMU, NF50-SVFU, NV50-SVFU	18kA	75A	18kA	NF100-HRU, NV100-HRU, NF125-SVU, NV125-SVU												
					14kA	14kA	NF50-SVFU, NV50-SVFU																
					18kA	18kA	NF100-SRU, NV100-SRU, NF100-HRU, NV100-HRU																
					25kA	35kA	NF100-HRU, NV100-HRU																
	35A		150A		10kA	50A	10kA	10kA	10kA	NF50-SMU, NF50-SVFU, NV50-SVFU	18kA	100A	18kA	NF100-HRU, NV100-HRU, NF125-SVU, NV125-SVU									
								14kA	14kA	NF50-SVFU, NV50-SVFU													
								18kA	18kA	NF100-SRU, NV100-SRU, NF100-HRU, NV100-HRU													
								25kA	35kA	NF100-HRU, NV100-HRU													
	42A		200A		10kA	50A	10kA	10kA	10kA	NF50-SMU, NF50-SVFU, NV50-SVFU	18kA	100A	18kA	NF100-HRU, NV100-HRU, NF125-SVU, NV125-SVU									
								14kA	14kA	NF50-SVFU, NV50-SVFU													
								18kA	18kA	NF100-SRU, NV100-SRU, NF100-HRU, NV100-HRU													
								25kA	35kA	NF100-HRU, NV100-HRU													
								35kA	100A	10kA					50A	10kA	10kA	10kA	NF50-SMU, NF50-SVFU, NV50-SVFU	35kA	50kA	50kA	NF125-HVU, NV125-HVU
																	14kA	14kA	NF50-SVFU, NV50-SVFU				
18kA	18kA	NF100-SRU, NV100-SRU, NF100-HRU, NV100-HRU																					
25kA	35kA	NF100-HRU, NV100-HRU																					
35kA	50kA	NF100-HRU, NV100-HRU																					



Thermal Overload Relays Model		Main circuit voltage:600VAC maximum		Main circuit voltage:240VAC maximum				Main circuit voltage:480VAC maximum					
		Short Circuit Current Rating (SCCR)	Maximum Rated Current of Fuse (Class K5)	Short Circuit Current Rating (SCCR)	circuit breakers			Short Circuit Current Rating (SCCR)	circuit breakers				
					Maximum Rated	Minimum Breaking Current	Recommended Model Name (Note 1)		Maximum Rated	Minimum Breaking Current	Recommended Model Name (Note 1)		
TH-T65KP	15A	5kA	70A	14kA	75A	14kA	NF100-CVFU	18kA	50A	18kA	NF100-HRU, NV100-HRU, NF125-SVU, NV125-SVU		
				18kA	50A	18kA	NF100-SRU, NV100-SRU, NF100-HRU, NV100-HRU				25kA	30kA	NF125-SVU, NF125-HVU
				25kA		30kA							NF125-SVU, NF125-HVU
	22A		100A	14kA	75A	14kA	NF100-CVFU	18kA	60A	18kA	NF100-HRU, NV100-HRU, NF125-SVU, NV125-SVU		
				18kA	60A	18kA	NF100-SRU, NV100-SRU, NF100-HRU, NV100-HRU				25kA	30kA	NF125-SVU, NF125-HVU
				25kA		30kA							NF125-SVU, NF125-HVU
	29A		125A	14kA	75A	14kA	NF100-CVFU	18kA	75A	18kA	NF100-HRU, NV100-HRU, NF125-SVU, NV125-SVU		
				18kA		18kA	NF100-SRU, NV100-SRU, NF100-HRU, NV100-HRU				25kA	30kA	NF125-SVU, NF125-HVU
				25kA		30kA							NF125-SVU, NF125-HVU
	35A		150A	14kA	75A	14kA	NF100-CVFU	18kA	75A	18kA	NF100-HRU, NV100-HRU, NF125-SVU, NV125-SVU		
				18kA		18kA	NF100-SRU, NV100-SRU, NF100-HRU, NV100-HRU				25kA	30kA	NF125-SVU, NF125-HVU
				25kA		30kA							NF125-SVU, NF125-HVU
	42A		200A	14kA	100A	14kA	NF100-CVFU	18kA	100A	18kA	NF100-HRU, NV100-HRU, NF125-SVU, NV125-SVU		
				18kA		18kA	NF100-SRU, NV100-SRU, NF100-HRU, NV100-HRU				25kA	30kA	NF125-SVU, NF125-HVU
				25kA		30kA							NF125-SVU, NF125-HVU
	54A		250A	14kA	100A	14kA	NF100-CVFU	18kA	100A	18kA	NF100-HRU, NV100-HRU, NF125-SVU, NV125-SVU		
				18kA		18kA	NF100-SRU, NV100-SRU, NF100-HRU, NV100-HRU				25kA	30kA	NF125-SVU, NF125-HVU
				25kA		30kA							NF125-SVU, NF125-HVU
10kA	225A	150A	150A	35kA	NF250-SVU	25kA	150A	35kA	NF250-SVU				
		150A		35kA	NF250-SVU								
		150A		35kA	NF250-SVU								
TH-T100KP	67A	5kA	300A	18kA	100A	18kA	NF100-SRU, NV100-SRU, NF100-HRU, NV100-HRU	18kA	100A	18kA	NF100-HRU, NV100-HRU, NF125-SVU, NV125-SVU		
		10kA	225A	25kA	225A	35kA	NF250-SVU, NV250-SVU	25kA	225A	35kA	NF250-SVU, NV250-SVU		
	82A	10kA	225A	18kA	100A	18kA	NF100-SRU, NV100-SRU, NF100-HRU, NV100-HRU	18kA	100A	18kA	NF100-HRU, NV100-HRU, NF125-SVU, NV125-SVU		
25kA				225A	35kA	NF250-SVU, NV250-SVU	25kA	225A	35kA	NF250-SVU, NV250-SVU			

Note 1: Examples of the recommended low-voltage breakers are given. Use a UL489-listed low-voltage breaker (3-pole part) that satisfies the ratings given above.

## Type Codes

\* For the information on type codes for orders, check the note in Order Procedure.

### Enclosed Magnetic Starters

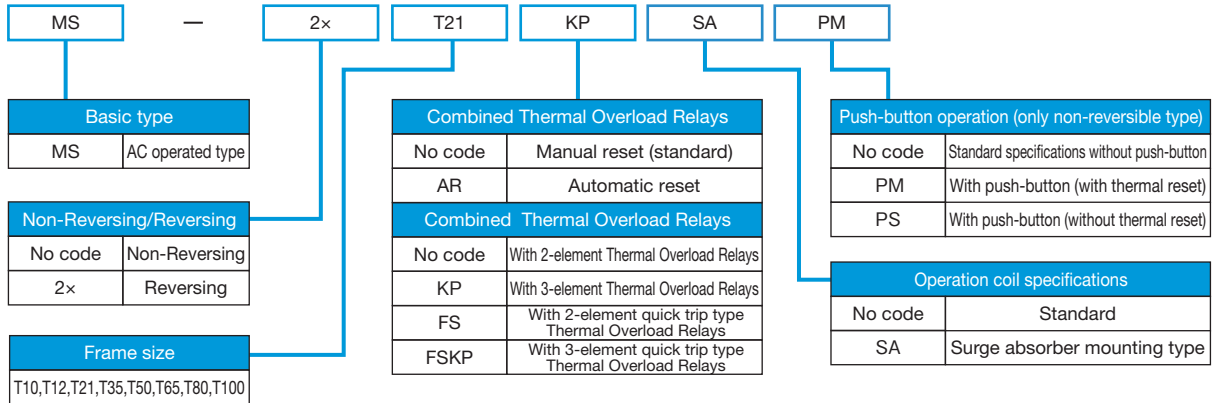

### Open type Magnetic Starters

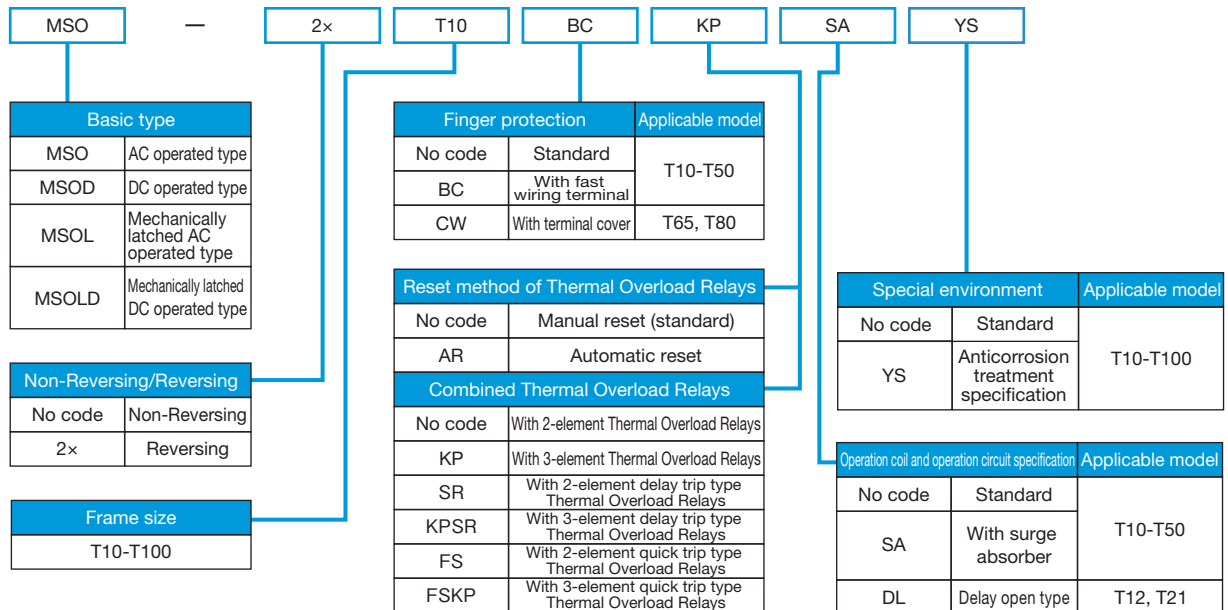

### Magnetic Contactors

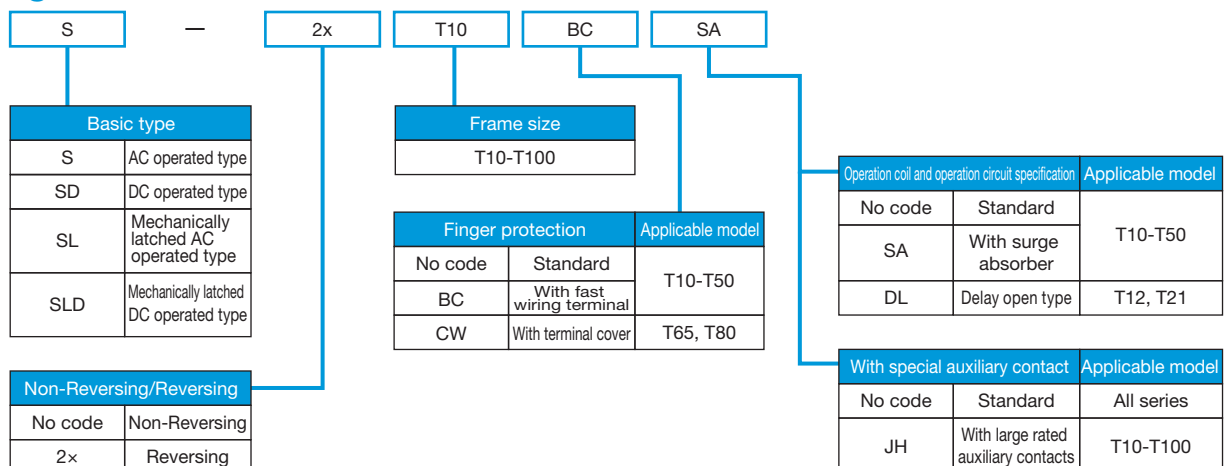

## Thermal Overload Relays

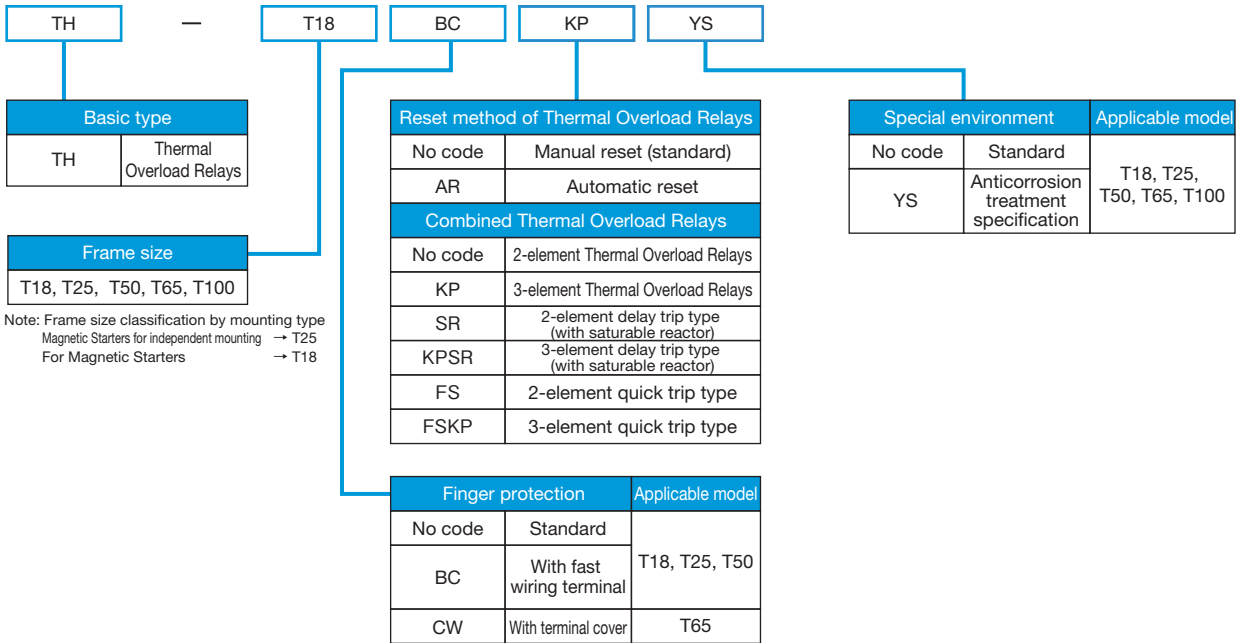

## Contactors Relays

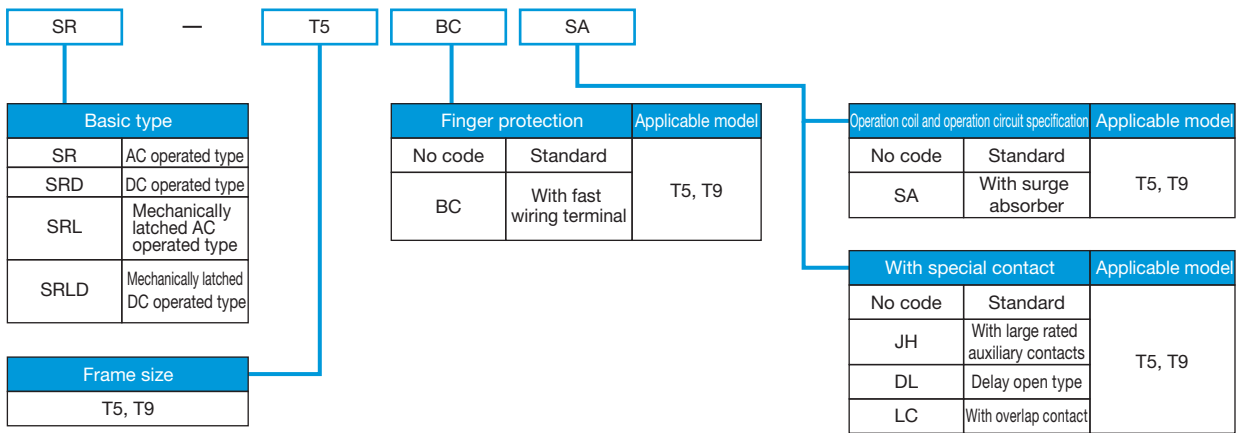

## Optional Units

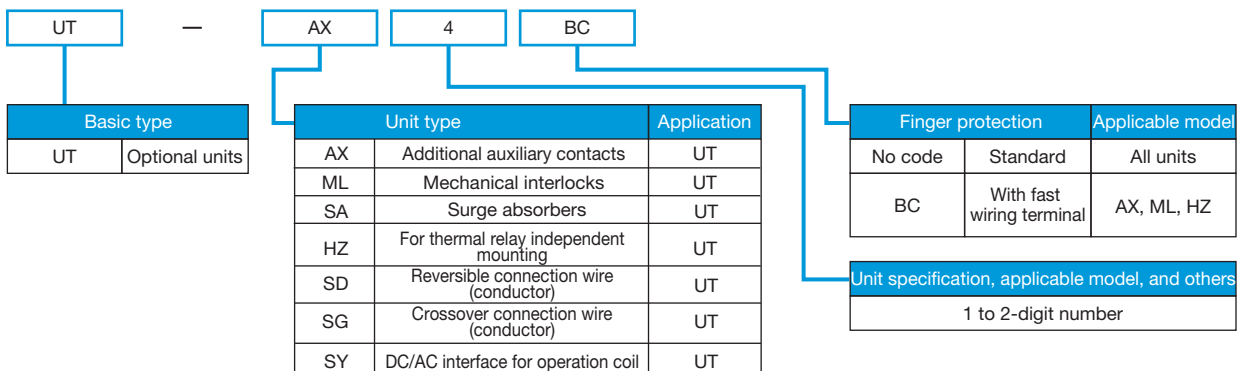

## Order Procedure

### Note

For orders, specify products as shown below. Insert a space where ▲ is present. If adding multiple two-character codes (such as SA, BC, and KP) after a frame size (T10 or others) of type name, specify them in alphabetical order of the first letters. (Example: MSO-T10BCKPSA)  
(If they are not in alphabetical order, the type code is automatically changed.)

### Enclosed Magnetic Starters

#### ● MS-(2×)T type

Model name	motor capacity	Main circuit voltage	Operation coil designation or operation circuit voltage	Auxiliary contact
MS-T21	▲ 3.7kW	▲ 200V	▲ AC200V	▲
MS-T10		▲ 200V	▲ AC200V	▲ 1B
Refer to page 18,50.	Select from page 18,26.	Do not add AC to the main circuit voltage. (To distinguish it from the operation circuit voltage)	Select coil designation from pages 22 or specify the working operation circuit voltage.	Select the auxiliary contact arrangements from page 18.

### Standard (AC operated) Magnetic Starters

#### ● MSO-(2×)T type

Model name	Heater designation (setting current)	Main circuit voltage	Operation coil designation or operation circuit voltage	Auxiliary contact
MSO-T21	▲ 3.7kW	▲ 200V	▲ AC200V	▲
MSO-T10	▲ 9A	▲ 200V	▲ AC200V	▲ 1B
Refer to page 18,20,50.	Select from page 18,20,26.	Do not add AC to the main circuit voltage. (To distinguish it from the operation circuit voltage)	Select coil designation from pages 22 or specify the working operation circuit voltage.	Select the auxiliary contact arrangements from page 18,20.

### Standard (AC operated) Magnetic Contactors

#### ● S-(2×)T types

Model name	Operation coil designation or operation circuit voltage	Auxiliary contact
S-T20	▲ AC200V	▲ 2A
S-T20	▲ AC100V50Hz	
Refer to page 18,20,50.	Select coil designation from pages 22 or specify the working operation circuit voltage.	Select the auxiliary contact arrangements from page 18,20.

### Contactors Relays

#### ● SR-T types

Model name	Operation coil designation	Contact arrangement
SR-T5	▲ AC200V	▲ 3A2B
SR-T5	▲ AC100V50Hz	▲ 4A1B
Refer to page 34.	Select coil designation from pages 22 or specify the working operation circuit voltage.	Designate the contact arrangement listed on page 34.

## Thermal Overload Relays

### ● TH-T type

Model name	Heater designation
TH-T18KP	▲ 15A
Refer to page 51.	Refer to page 26 and designate the heater nominal.

## Optional Units

### ● UT-AX□ auxiliary contact block

Model name	Contact arrangement
UT-AX4	▲ 2A2B
Refer to page 37.	Designate the contact arrangement listed on page 37 for the UT-AX2/AX4. UT-AX11 does not need to be designated as 1A1B is fixed.

### ● UT-SA□ Operation Coil Surge Absorber Unit

Model name	Voltage nominal
UT-SA21	▲ AC400V
UT-SA22	▲ AC200V
UT-SA25	▲ AC48V
Refer to page 38.	Select according to the operation circuit voltage.

### ● UT-ML□ Mechanical Interlock Unit

Model name
UT-ML11
Refer to page 39.

### ● UT-SY□ (BC) type DC/AC interface unit for operation coil

Model name
UT-SY21
UT-SY21BC
Refer to page 41.

### ● UT-HZ18 (BC), UN-RM20 type Independent mounting unit for thermal relay

Model name
UT-HZ18
UT-RM20
Refer to page 39.

## Outline Drawing, Contact Arrangement

### Magnetic Starters (enclosed)

#### Non-reversing Magnetic Starter (enclosed)

Enclosure (case): Steel  
 Paint color: Munsell 5Y7/1  
 Protective structure: IP20

- MS-T10 type
- MS-T12 type

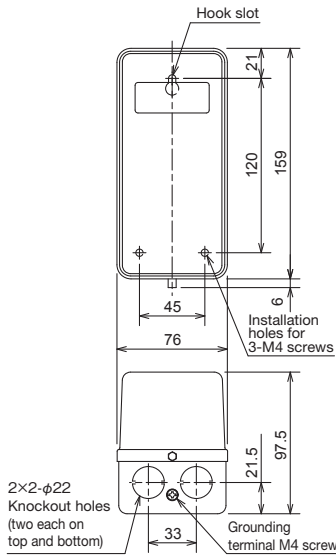

- \*1. When mounting the MS-T10 to T50 types, leave 100mm of space below the box.
- \*2. The MS-T10 to T50 types have three rubber bushings enclosed.

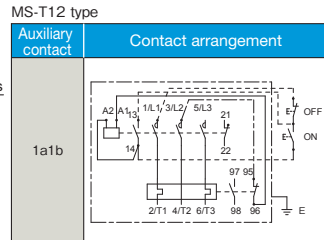
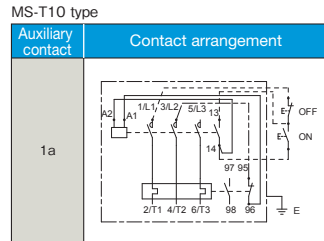

- Note 1) The above figure gives an example of when the main circuit and operating circuit use the same power supply. The solid line is already wired. The dashed line and two-dot chain line sections must be wired. (Use the wires enclosed with the unit to wire the two-dot chain line sections.)
- Note 2) If the power supply is different for the main circuit and operating circuit, do not wire between the dashed line 1/L1 and OFF button and between the two-dot chain line 3/L2 and TH95. Wire to the OFF button and TH95 terminal from a different operating circuit power supply.

- MS-T21, T25 type

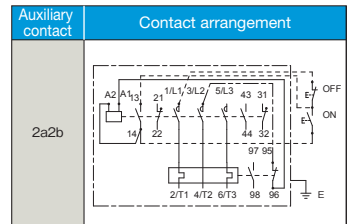
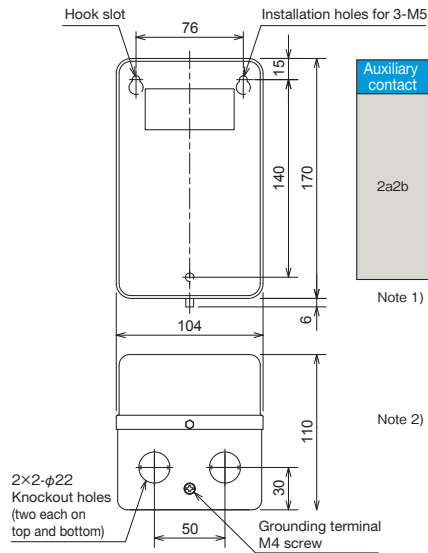

- Note 1) The above figure gives an example of when the main circuit and operating circuit use the same power supply. The solid line is already wired. The dashed line and two-dot chain line sections must be wired. (Use the wires enclosed with the unit to wire the two-dot chain line sections.)
- Note 2) If the power supply is different for the main circuit and operating circuit, do not wire between the dashed line 1/L1 and OFF button and between the two-dot chain line 3/L2 and TH95. Wire to the OFF button and TH95 terminal from a different operating circuit power supply.

- \*1. When mounting the MS-T10 to T21 types, leave 100mm of space below the box.
- \*2. The MS-T10 to T21 types have three rubber bushings enclosed.

- MS-T35, T50 type

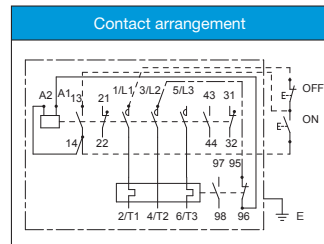
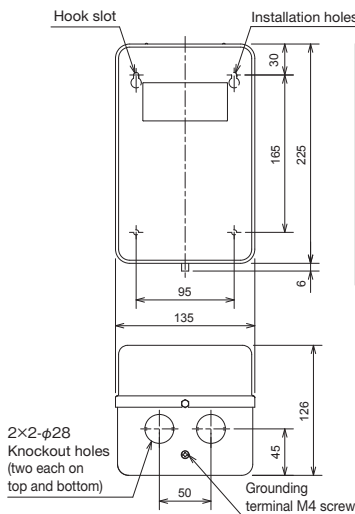

- Note 1) The above figure gives an example of when the main circuit and operating circuit use the same power supply. The solid line is already wired. The dashed line and two-dot chain line sections must be wired. (Use the wires enclosed with the unit to wire the two-dot chain line sections.)
- Note 2) If the power supply is different for the main circuit and operating circuit, do not wire between the dashed line 1/L1 and OFF button and between the two-dot chain line 3/L2 and TH95. Wire to the OFF button and TH95 terminal from a different operating circuit power supply.

- MS-T65 to T100 type

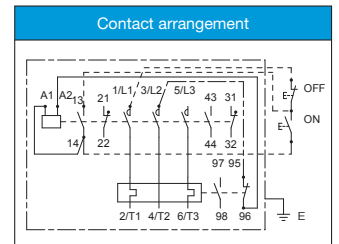
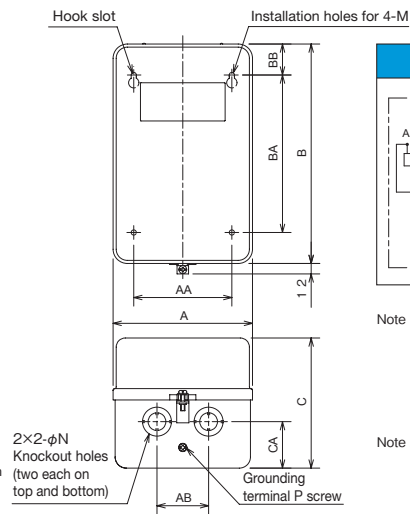

- Note 1) The above figure gives an example of when the main circuit and operating circuit use the same power supply. The solid line is already wired. The dashed line and two-dot chain line sections must be wired. (Use the wires enclosed with the unit to wire the two-dot chain line sections.)
- Note 2) If the power supply is different for the main circuit and operating circuit, do not wire between the dashed line 1/L1 and OFF button and between the two-dot chain line 3/L2 and TH95. Wire to the OFF button and TH95 terminal from a different operating circuit power supply.

Model	Dimensions											Weight (kg)
	A	AA	AB	B	BA	BB	C	CA	M	N	P	
MS-T65/T80	160	120	80	270	220	25	145	45	M5	22-35	M4	2.9/2.9
MS-T100	190	150	100	305	260	25	163	67	M6	22-35	M4	4.0/4.0

## Reversing Magnetic Starter (enclosed)

Enclosure (case): Steel  
 Paint color: Munsell 5Y7/1  
 Protective structure: IP20

### MS-2xT21, T25 type

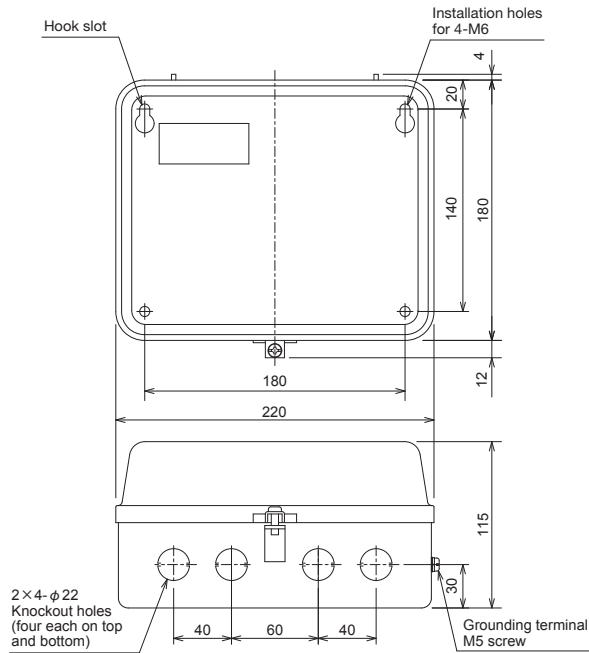

\*1. The MS-2xT21 to T50 type has three rubber bushings enclosed.

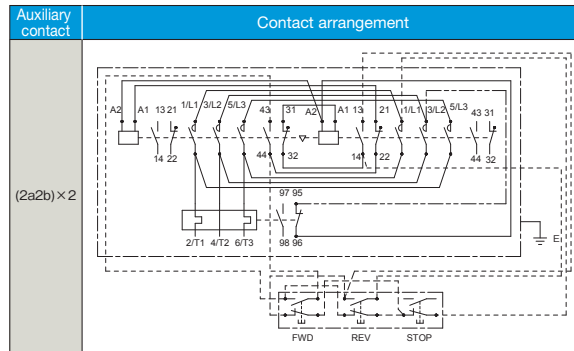

- Note 1) The above figure gives an example of when the main circuit and operating circuit use the same power supply. The solid line is already wired. The dashed line and two-dot chain line sections must be wired. (Use the wires enclosed with the unit to wire the two-dot chain line sections.)
- Note 2) If the power supply is different for the main circuit and operating circuit, do not wire between the dashed line 1/L1 and STOP button and between the two-dot chain line 3/L2 and TH95. Wire to the STOP button and TH95 terminal from a different operating circuit power supply.

### MS-2xT35 to T100 type

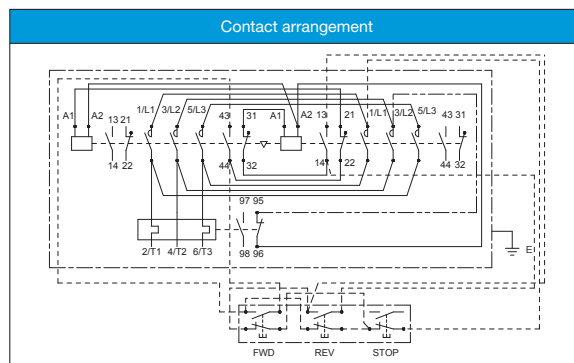
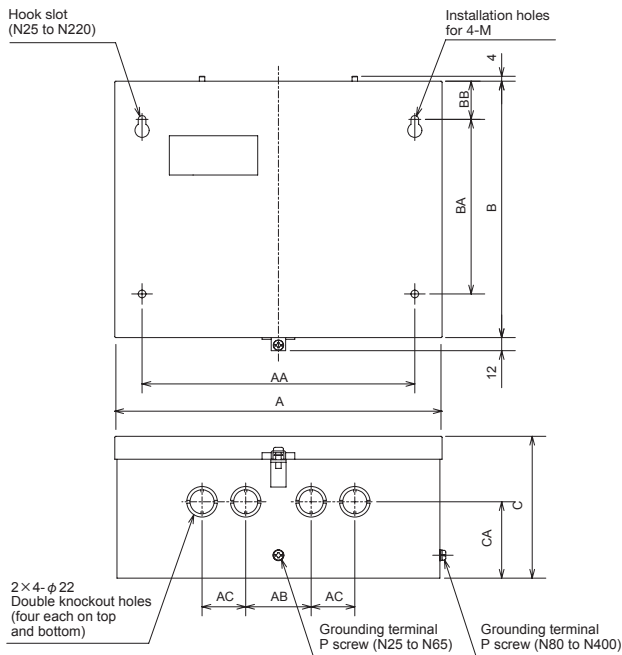

- Note 1) The above figure gives an example of when the main circuit and operating circuit use the same power supply. The solid line is already wired. The dashed line and two-dot chain line sections must be wired. (Use the wires enclosed with the unit to wire the two-dot chain line sections.)
- Note 2) If the power supply is different for the main circuit and operating circuit, do not wire between the dashed line 1/L1 and OFF button and between the two-dot chain line 3/L2 and TH95. Wire to the OFF button and TH95 terminal from a different operating circuit power supply.

Model	Dimensions											Weight (kg)		
	A	AA	AB	AC	B	BA	BB	C	CA	M	N		O	P
MS-2xT35/T50	300	25	60	40	235	160	35	130	70	M6	22-28	4	M5	4.6/4.6
MS-2xT65/T80	320	270	100	60	270	240	15	140	70	M6	22-35	4	M6	6.6/6.6
MS-2xT100	410	350	140	60	335	270	35	154	87	M6	22-35	4	M6	10/10

MS-T Series Introduction

Selection and Application

Application to Thermal Overcut Relays

Product Introduction

Overseas Standard

Type Codes

Order Procedure

Outline Drawing

Warranty and Safety

## Outline Drawing, Contact Arrangement

### Magnetic Contactors • Starters (AC operated)

#### MSO-T10(BC)

Non-Reversing

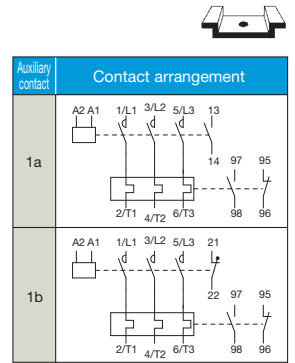
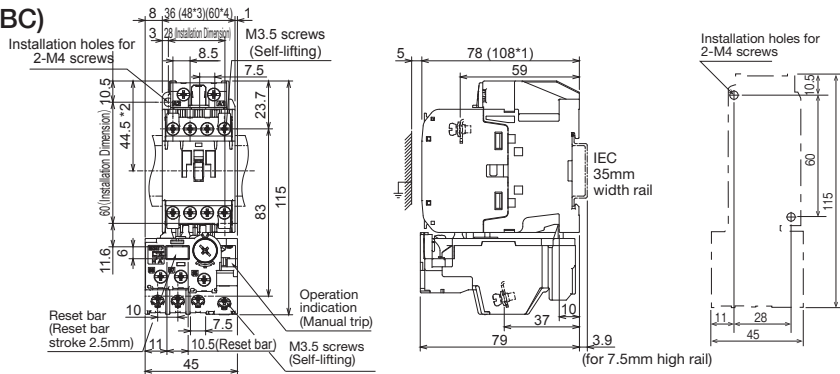

\*1 dimensions: With head mounted auxiliary contact unit (UT-AX2(BC), UT-AX4(BC))  
 \*2 dimensions: Dimensions from center of IEC 35mm width rail  
 \*3, \*4 dimensions: With side mounted auxiliary contact unit (UT-AX11(BC)) ... \*3 shows dimension for one unit, and \*4 shows dimensions with two units (both sides).

#### MSO-2xT10(BC)

Reversing

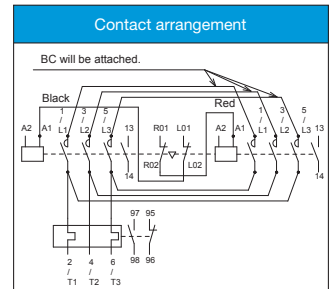
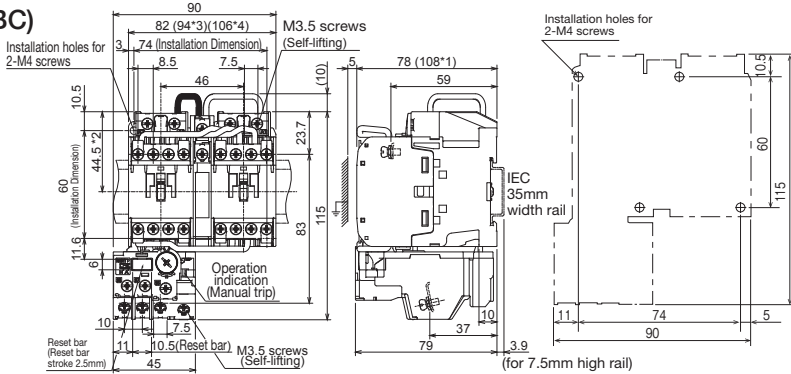

\*1 dimensions: With head mounted auxiliary contact unit (UT-AX2(BC), UT-AX4(BC))  
 \*2 dimensions: Dimensions from center of IEC 35mm width rail  
 \*3, \*4 dimensions: With side mounted auxiliary contact unit (UT-AX11(BC)) ... \*3 shows dimension for one unit, and \*4 shows dimensions with two units (both sides).

#### S-T10(BC)

Non-Reversing

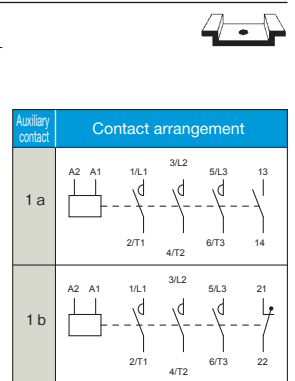
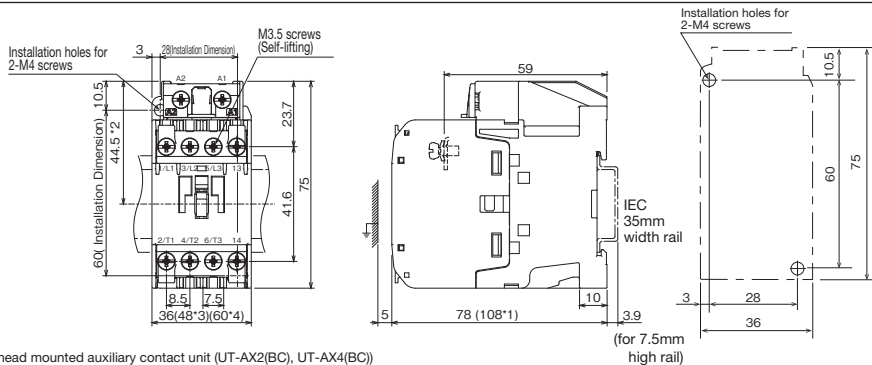

\*1 dimensions: With head mounted auxiliary contact unit (UT-AX2(BC), UT-AX4(BC))  
 \*2 dimensions: Dimensions from center of IEC 35mm width rail  
 \*3, \*4 dimensions: With side mounted auxiliary contact unit (UT-AX11(BC)) ... \*3 shows dimension for one unit, and \*4 shows dimensions with two units (both sides).

#### S-2xT10(BC)

Reversing

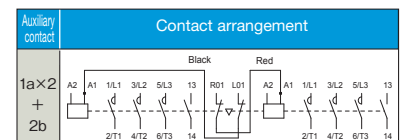
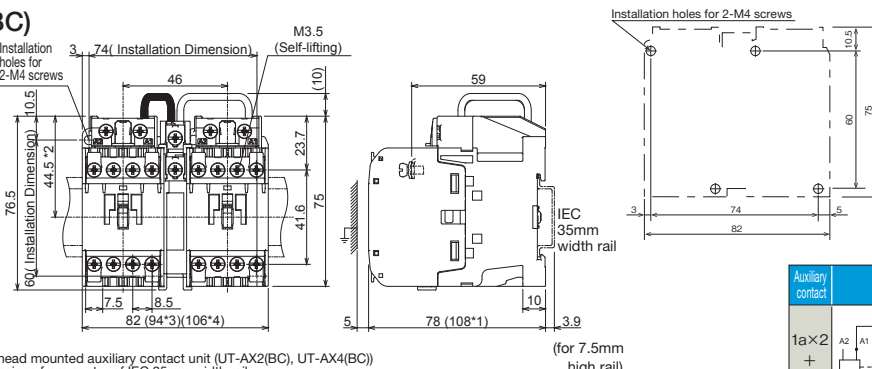

\*1 dimensions: With head mounted auxiliary contact unit (UT-AX2(BC), UT-AX4(BC))  
 \*2 dimensions: Dimensions from center of IEC 35mm width rail  
 \*3, \*4 dimensions: With side mounted auxiliary contact unit (UT-AX11(BC)) ... \*3 shows dimension for one unit, and \*4 shows dimensions with two units (both sides).



● MSO-T12(BC)  
● MSO-T20(BC)

non-Reversing

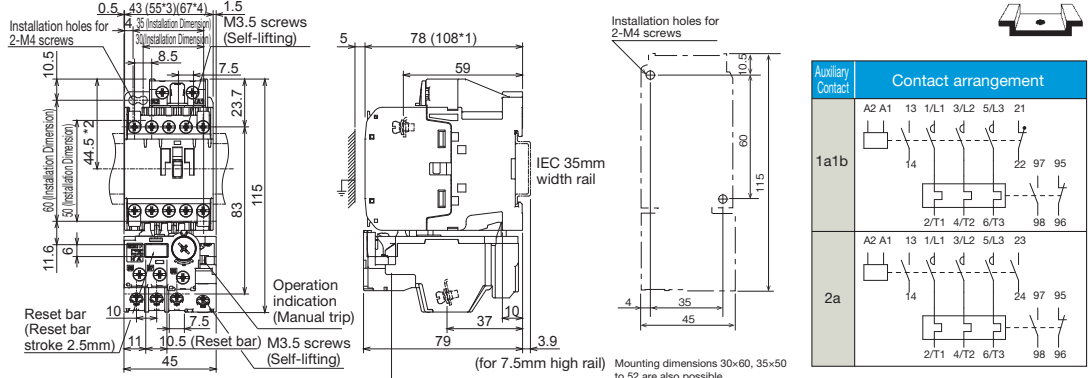

\*1 dimensions: With head mounted auxiliary contact unit (UT-AX2(BC), UT-AX4(BC))  
\*2 dimensions: Dimensions from center of IEC 35mm width rail  
\*3, \*4 dimensions: With side mounted auxiliary contact unit (UT-AX11(BC)) ... \*3 shows dimension for one unit, and \*4 shows dimensions with two units (both sides).

● MSO-2xT12(BC)  
● MSO-2xT20(BC)

Reversing

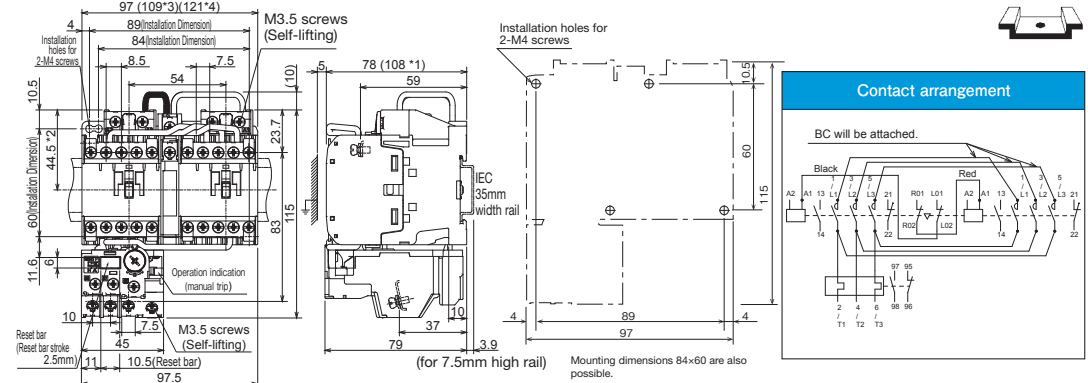

\*1 dimensions: With head mounted auxiliary contact unit (UT-AX2(BC), UT-AX4(BC))  
\*2 dimensions: Dimensions from center of IEC 35mm width rail  
\*3, \*4 dimensions: With side mounted auxiliary contact unit (UT-AX11(BC)) ... \*3 shows dimension for one unit, and \*4 shows dimensions with two units (both sides).

● S-T12(BC)  
● S-T20(BC)

non-Reversing

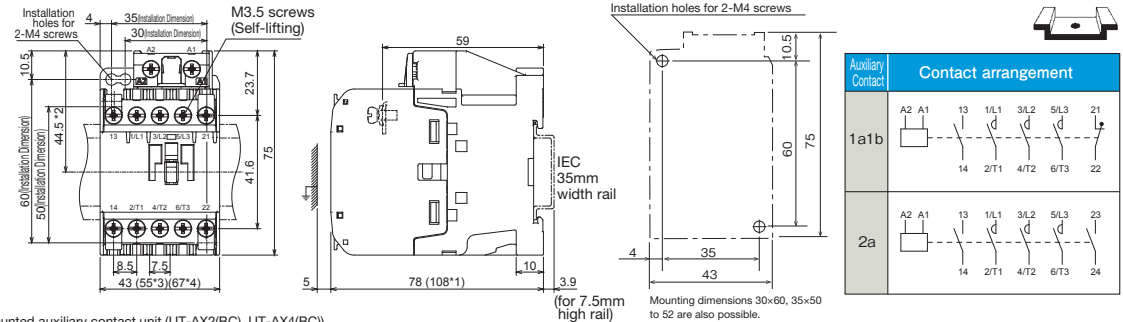

\*1 dimensions: With head mounted auxiliary contact unit (UT-AX2(BC), UT-AX4(BC))  
\*2 dimensions: Dimensions from center of IEC 35mm width rail  
\*3, \*4 dimensions: With side mounted auxiliary contact unit (UT-AX11(BC)) ... \*3 shows dimension for one unit, and \*4 shows dimensions with two units (both sides).

● S-2xT12(BC)  
● S-2xT20(BC)

Reversing

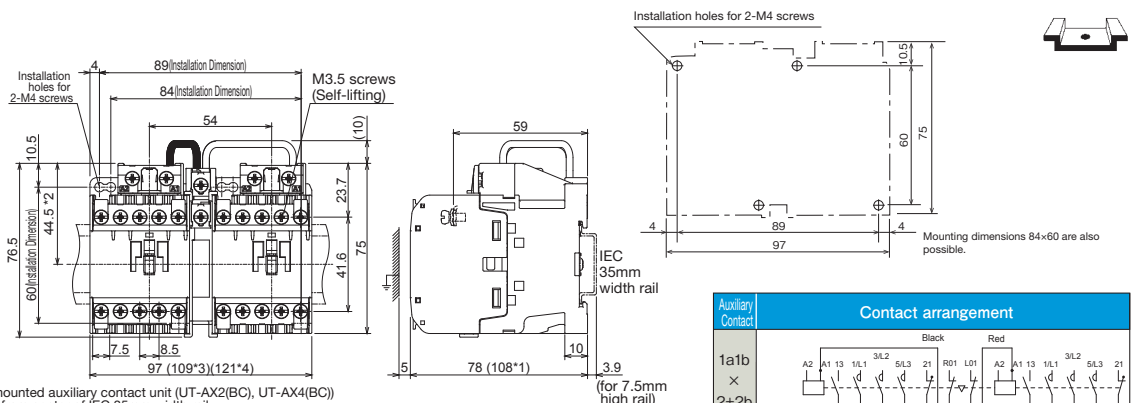

\*1 dimensions: With head mounted auxiliary contact unit (UT-AX2(BC), UT-AX4(BC))  
\*2 dimensions: Dimensions from center of IEC 35mm width rail  
\*3, \*4 dimensions: With side mounted auxiliary contact unit (UT-AX11(BC)) ... \*3 shows dimension for one unit, and \*4 shows dimensions with two units (both sides).

MS-T Series Introduction

Selection and Application

Application to Thermal Overcurrent Relays

Product Introduction

Overseas Standard

Type Codes

Order Procedure

Outline Drawing

Warranty and Safety

## Outline Drawing, Contact Arrangement

### Magnetic Contactors • Starters (AC operated)

- MSO-T21(BC)
- MSO-T25(BC)

non-Reversing

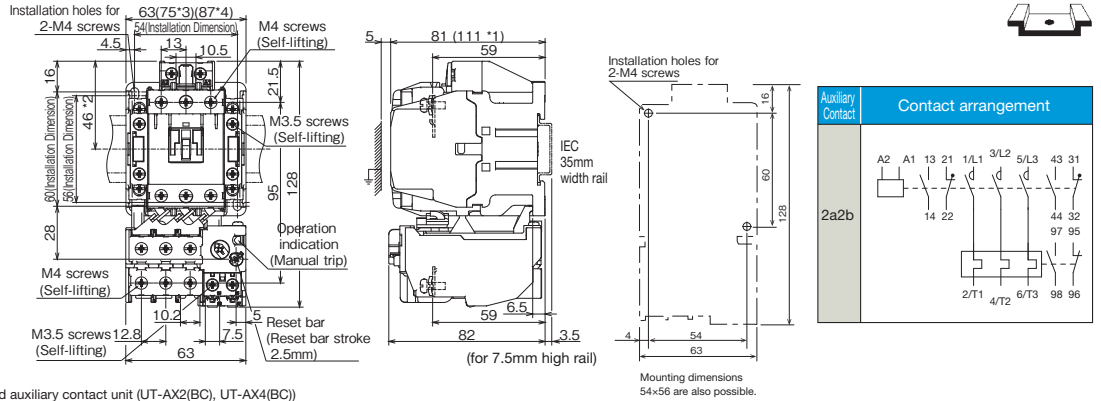

\*1 dimensions: With head mounted auxiliary contact unit (UT-AX2(BC), UT-AX4(BC))  
 \*2 dimensions: Dimensions from center of IEC 35mm width rail  
 \*3, \*4 dimensions: With side mounted auxiliary contact unit (UT-AX11(BC)) ... \*3 shows dimension for one unit, and \*4 shows dimensions with two units (both sides).

- MSO-2xT21(BC)
- MSO-2xT25(BC)

Reversing

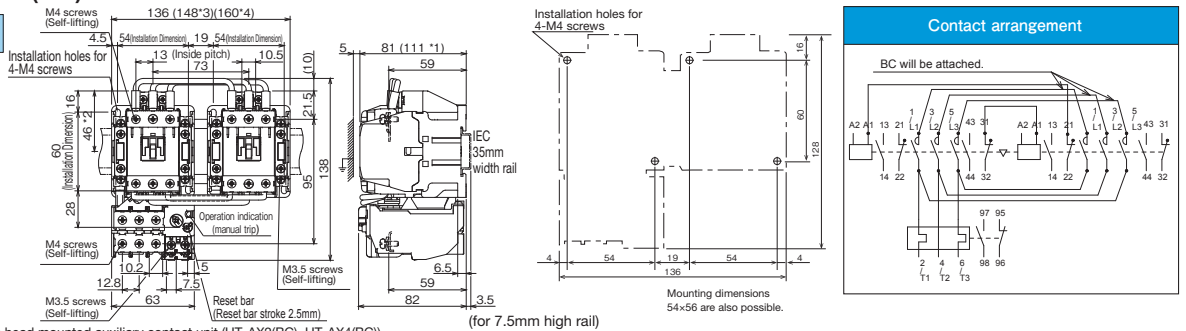

\*1 dimensions: With head mounted auxiliary contact unit (UT-AX2(BC), UT-AX4(BC))  
 \*2 dimensions: Dimensions from center of IEC 35mm width rail  
 \*3, \*4 dimensions: With side mounted auxiliary contact unit (UT-AX11(BC)) ... \*3 shows dimension for one unit, and \*4 shows dimensions with two units (both sides).

- S-T21(BC)
- S-T25(BC)

non-Reversing

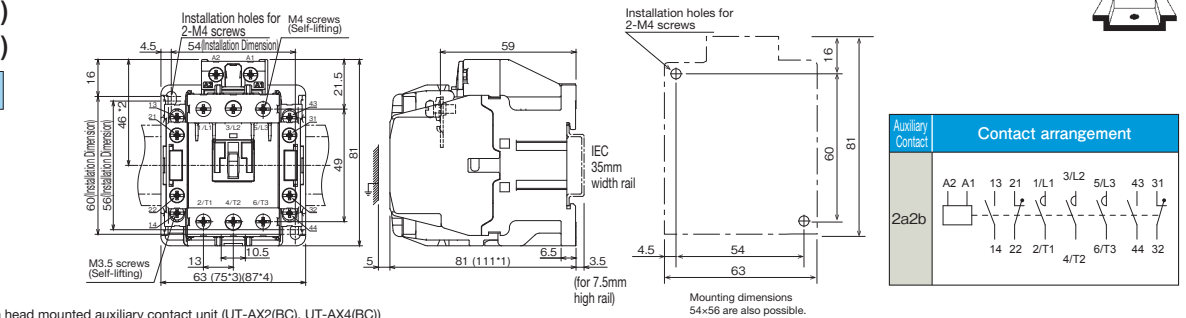

\*1 dimensions: With head mounted auxiliary contact unit (UT-AX2(BC), UT-AX4(BC))  
 \*2 dimensions: Dimensions from center of IEC 35mm width rail  
 \*3, \*4 dimensions: With side mounted auxiliary contact unit (UT-AX11(BC)) ... \*3 shows dimension for one unit, and \*4 shows dimensions with two units (both sides).

- S-2xT21(BC)
- S-2xT25(BC)

Reversing

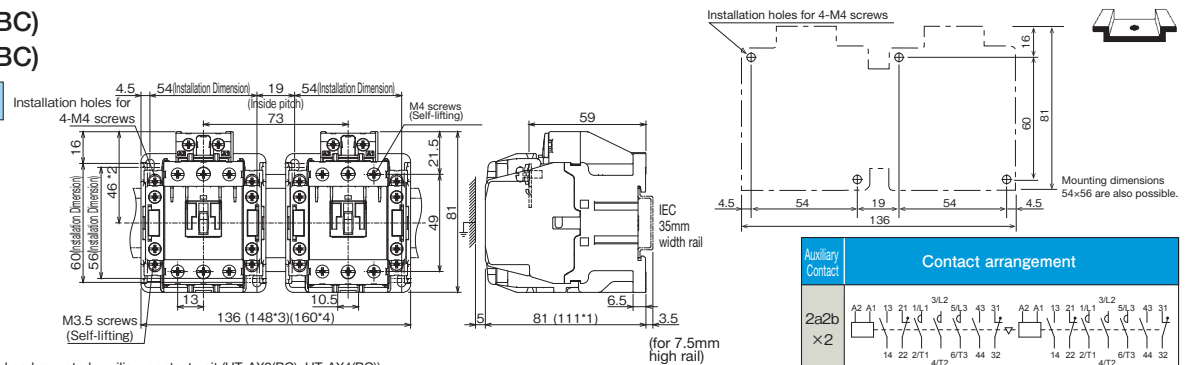

\*1 dimensions: With head mounted auxiliary contact unit (UT-AX2(BC), UT-AX4(BC))  
 \*2 dimensions: Dimensions from center of IEC 35mm width rail  
 \*3, \*4 dimensions: With side mounted auxiliary contact unit (UT-AX11(BC)) ... \*3 shows dimension for one unit, and \*4 shows dimensions with two units (both sides).



## Outline Drawing, Contact Arrangement

### Magnetic Contactors • Starters (AC operated)

- S-T35(BC)
- S-T50(BC)

non-Reversing

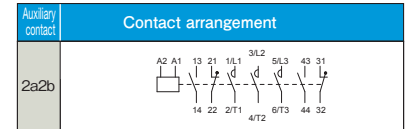
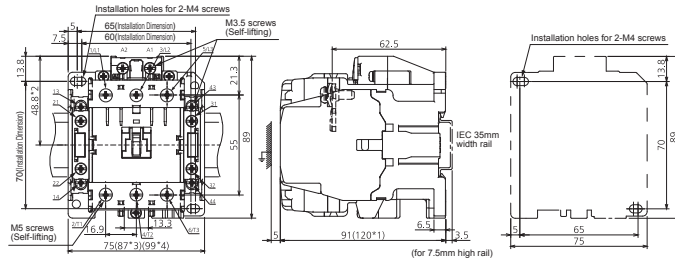

\*1 dimensions: With head mounted auxiliary contact unit (UT-AX2, UT-AX4)  
 \*2 dimensions: Dimensions from center of IEC 35mm width rail  
 \*3, \*4 dimensions: With side mounted auxiliary contact unit (UT-AX11) ... \*3 shows dimension for one unit, and \*4 shows dimensions with two units (both sides).

- S-2×T35(BC)
- S-2×T50(BC)

Reversing

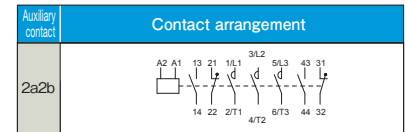
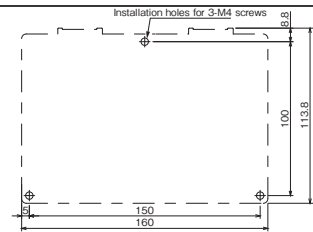
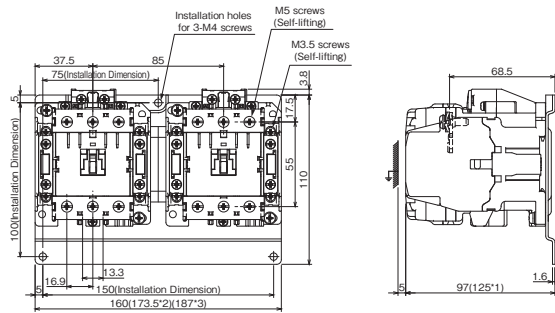

\*1 dimensions: With head mounted auxiliary contact unit (UT-AX2, UT-AX4)  
 \*2, \*3 dimensions: With side mounted auxiliary contact unit (UT-AX11) ... \*2 shows dimension for one unit, and \*3 shows dimensions with two units (both sides).

- MSO-T65
- MSO-T80

non-Reversing

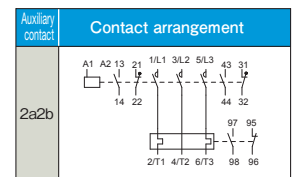
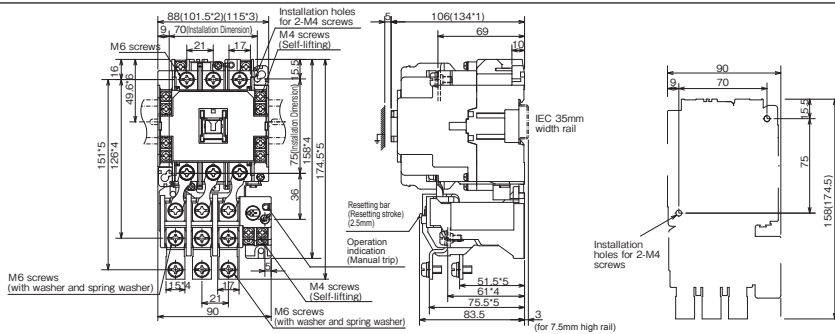

\*1 dimensions: With head mounted auxiliary contact unit (UT-AX2, UT-AX4)  
 \*2, \*3 dimensions: With side mounted auxiliary contact unit (UT-AX11) ... \*2 shows dimension for one unit, and \*3 shows dimensions with two units (both sides).  
 \*4 dimensions: Dimensions for heater nominal 54A or less  
 \*5 dimensions: Dimensions for heater nominal 67A  
 \*6 dimensions: Dimensions from center of IEC 35mm width rail

- MSO-2×T65
- MSO-2×T80

Reversing

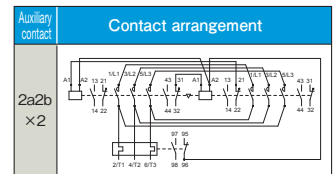
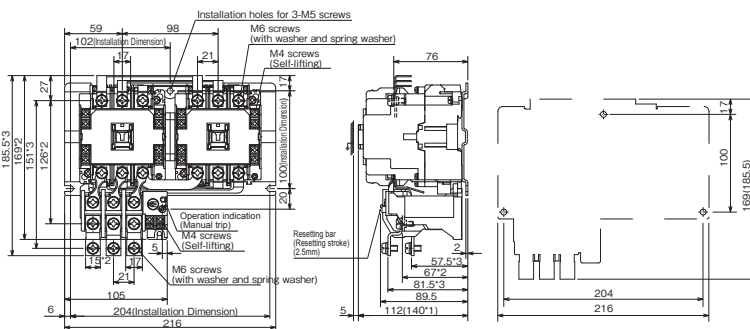

\*1 dimensions: With head mounted auxiliary contact unit (UT-AX2, UT-AX4)  
 \*2 dimensions: Dimensions for heater nominal 54A or less  
 \*3 dimensions: Dimensions for heater nominal 67A



## Outline Drawing, Contact Arrangement

### Magnetic Contactors · Starters (AC operated)

#### ● S-T100

non-Reversing

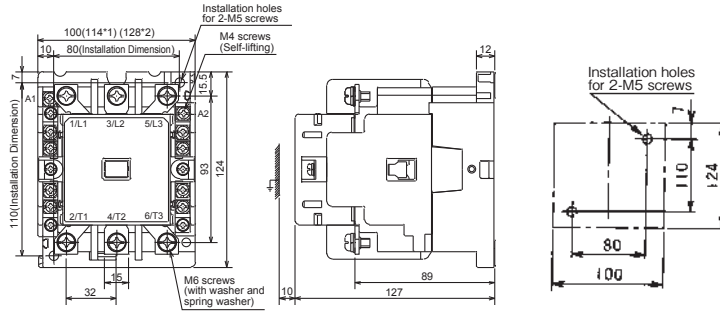

\*1, \*2 dimensions: With side mounted auxiliary contact unit (UT-AX11) ... \*1 shows dimension for one unit, and \*2 shows dimensions with two units (both sides).

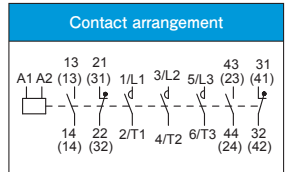

#### ● S-2×T100

Reversing

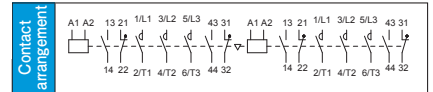
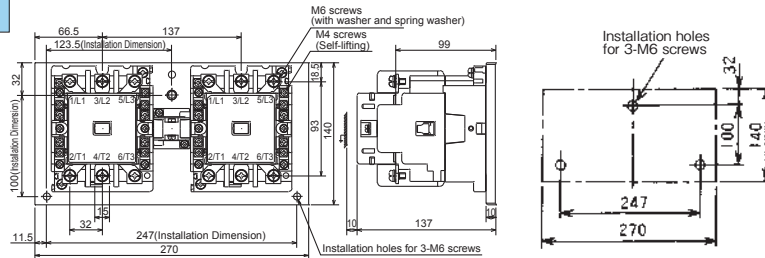

## Magnetic Contactor • Starters (DC operated)

- SD-T12(BC)
- SD-T20(BC)

non-Reversing

Installation holes for 2-M4 screws

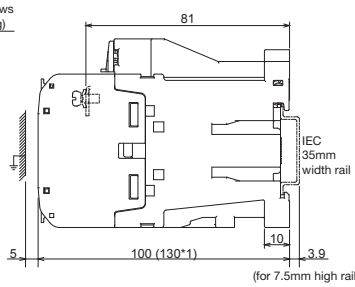
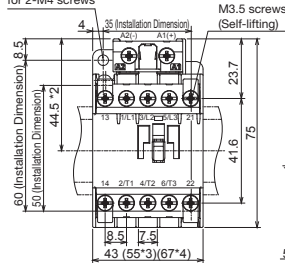

Installation holes for 2-M4 screws

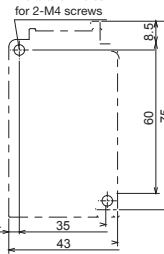

(for 7.5mm high rail)  
Mounting dimensions 35x50 to 52 are also possible.

Auxiliary contact	Contact arrangement
1a1b	
2a	

\*1 dimensions: With head mounted auxiliary contact unit (UT-AX2(BC), UT-AX4(BC))  
\*2 dimensions: Dimensions from center of IEC 35mm width rail  
\*3, \*4 dimensions: With side mounted auxiliary contact unit (UT-AX11(BC)) ... \*3 shows dimension for one unit, and \*4 shows dimensions with two units (both sides).

- SD-2xT12(BC)
- SD-2xT20(BC)

Reversing

Installation holes for 2-M4 screws

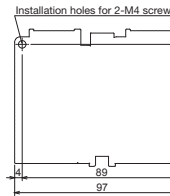
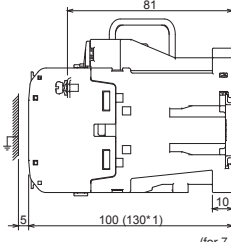
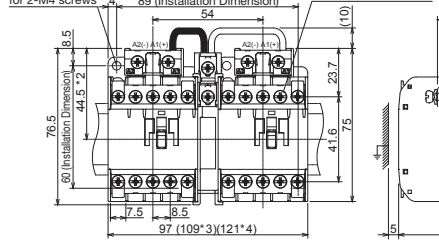

(for 7.5mm high rail)

Auxiliary contact	Contact arrangement
1a1b × 2+2b	

\*1 dimensions: With head mounted auxiliary contact unit (UT-AX2(BC), UT-AX4(BC))  
\*2 dimensions: Dimensions from center of IEC 35mm width rail  
\*3, \*4 dimensions: With side mounted auxiliary contact unit (UT-AX11(BC)) ... \*3 shows dimension for one unit, and \*4 shows dimensions with two units (both sides).

- MSOD-T12(BC)
- MSOD-T20(BC)

non-Reversing

Installation holes for 2-M4 screws

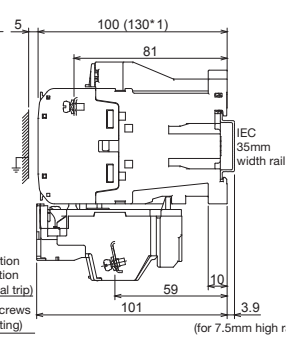
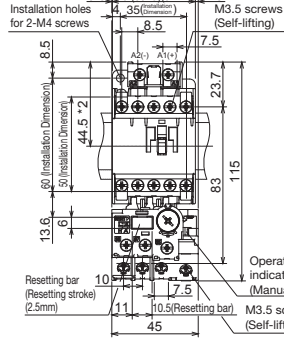

Installation holes for 2-M4 screws

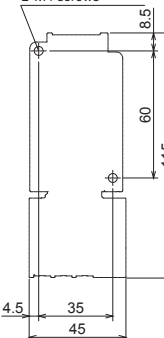

(for 7.5mm high rail)

Auxiliary contact	Contact arrangement
1a1b	
2a	

\*1 dimensions: With head mounted auxiliary contact unit (UT-AX2(BC), UT-AX4(BC))  
\*2 dimensions: Dimensions from center of IEC 35mm width rail  
\*3, \*4 dimensions: With side mounted auxiliary contact unit (UT-AX11(BC)) ... \*3 shows dimension for one unit, and \*4 shows dimensions with two units (both sides).

- MSOD-2xT12(BC)
- MSOD-2xT20(BC)

Reversing

Installation holes for 2-M4 screws

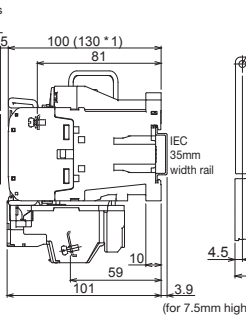
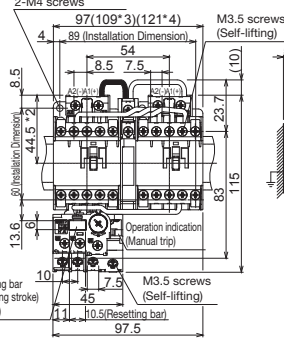

Installation holes for 2-M4 screws

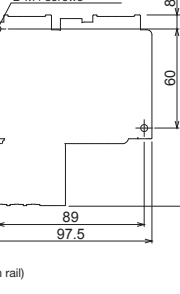

(for 7.5mm high rail)

Contact arrangement

\*1 dimensions: With head mounted auxiliary contact unit (UT-AX2(BC), UT-AX4(BC))  
\*2 dimensions: Dimensions from center of IEC 35mm width rail  
\*3, \*4 dimensions: With side mounted auxiliary contact unit (UT-AX11(BC)) ... \*3 shows dimension for one unit, and \*4 shows dimensions with two units (both sides).

MS-T Series Introduction

Selection and Application

Application to Thermal Overcut Relays

Product Introduction

Overseas Standard

Type Codes

Order Procedure

Outline Drawing

Warranty and Safety

## Outline Drawing, Contact Arrangement

### Magnetic Contactor · Starters (DC operated)

#### ● SD-T21(BC)

non-Reversing

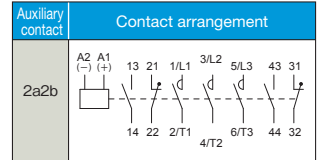
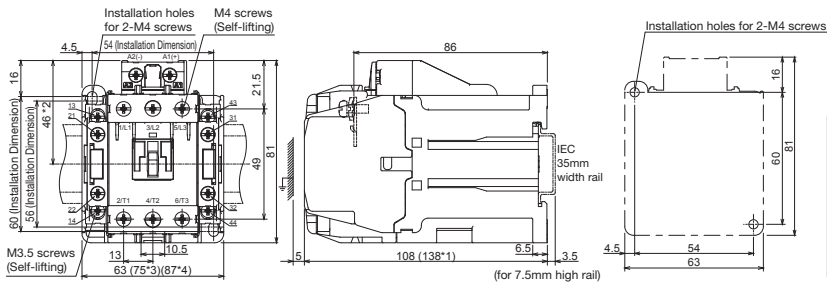

- \*1 dimensions: With head mounted auxiliary contact unit (UT-AX2(BC), UT-AX4(BC))
- \*2 dimensions: Dimensions from center of IEC 35mm width rail
- \*3, \*4 dimensions: With side mounted auxiliary contact unit (UT-AX11(BC)) ... \*3 shows dimension for one unit, and \*4 shows dimensions with two units (both sides).

#### ● SD-2xT21(BC)

Reversing

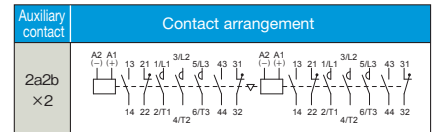
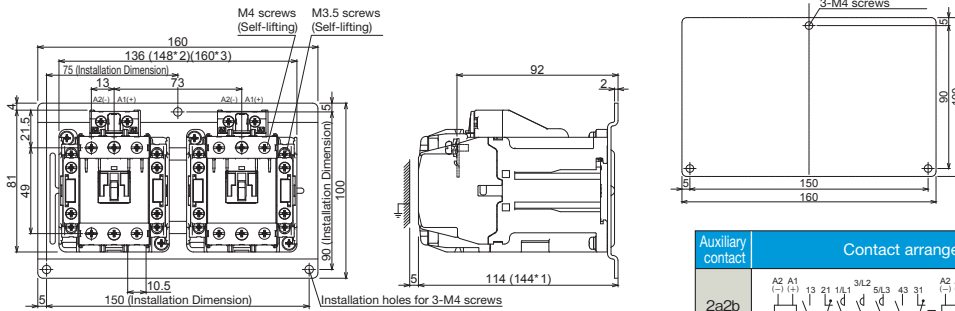

- \*1 dimensions: With head mounted auxiliary contact unit (UT-AX2(BC), UT-AX4(BC))
- \*2, \*3 dimensions: With side mounted auxiliary contact unit (UT-AX11(BC)) ... \*2 shows dimension for one unit, and \*3 shows dimensions with two units (both sides).

#### ● MSOD-T21(BC)

non-Reversing

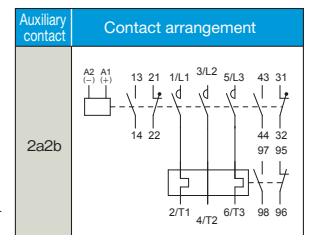
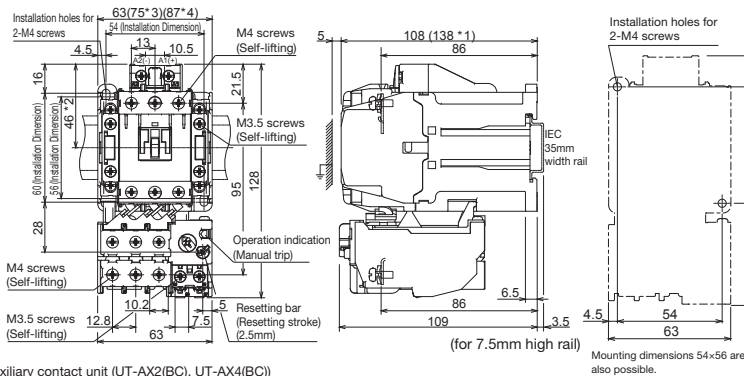

- \*1 dimensions: With head mounted auxiliary contact unit (UT-AX2(BC), UT-AX4(BC))
- \*2 dimensions: Dimensions from center of IEC 35mm width rail
- \*3, \*4 dimensions: With side mounted auxiliary contact unit (UT-AX11(BC)) ... \*3 shows dimension for one unit, and \*4 shows dimensions with two units (both sides).

#### ● MSOD-2xT21(BC)

Reversing

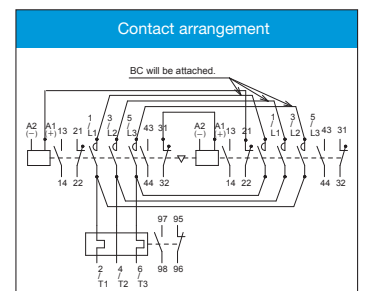
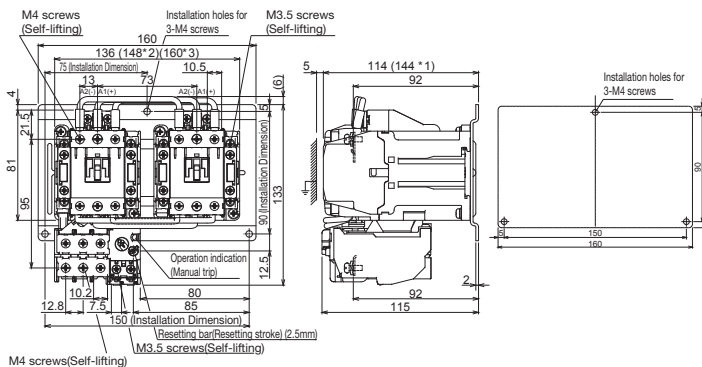

- \*1 dimensions: With head mounted auxiliary contact unit (UT-AX2(BC), UT-AX4(BC))
- \*2, \*3 dimensions: With side mounted auxiliary contact unit (UT-AX11(BC)) ... \*2 shows dimension for one unit, and \*3 shows dimensions with two units (both sides).





## Outline Drawing, Contact Arrangement

### Magnetic Contactor · Starters (DC operated)

- MSOD-T35(BC)
- MSOD-T50(BC)

non-Reversing

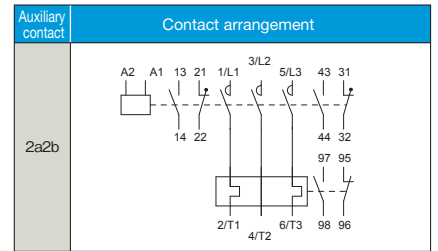
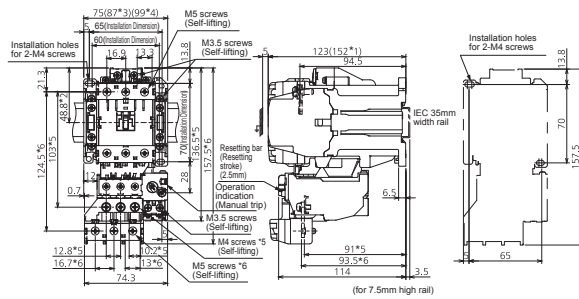

\*1 dimensions: With head mounted auxiliary contact unit (UT-AX2, UT-AX4)  
 \*2 dimensions: Dimensions from center of IEC 35mm width rail  
 \*3, \*4 dimensions: With side mounted auxiliary contact unit (UT-AX11) ... \*3 shows dimension for one unit, and \*4 shows dimensions with two units (both sides).  
 \*5 dimensions: Heater nominal 22A or less, \*6 dimensions: Heater nominal 29A or more

- MSOD-2xT35(BC)
- MSOD-2xT50(BC)

Reversing

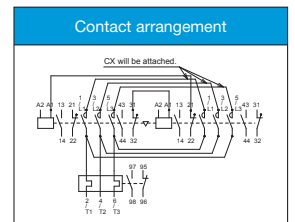
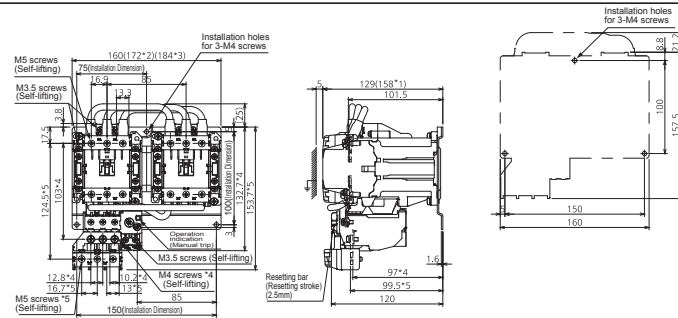

\*1 dimensions: With head mounted auxiliary contact unit (UT-AX2, UT-AX4)  
 \*2, \*3 dimensions: With side mounted auxiliary contact unit (UT-AX11) ... \*2 shows dimension for one unit, and \*3 shows dimensions with two units (both sides).  
 \*4 dimensions: Heater nominal 22A or less, \*6 dimensions: Heater nominal 29A or more

- SD-T65
- SD-T80

non-Reversing

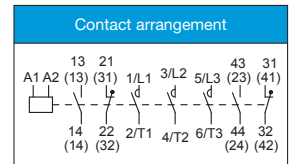
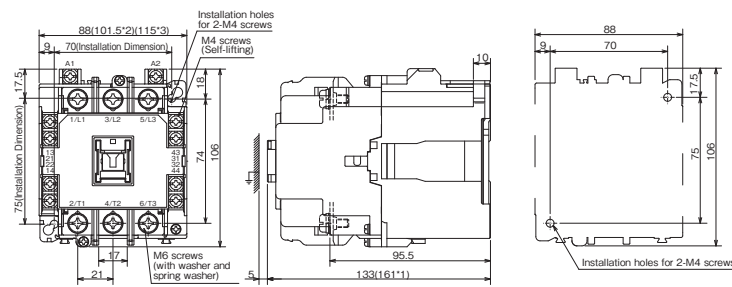

\*1 dimensions: With head mounted auxiliary contact unit (UT-AX2, UT-AX4)  
 \*2, \*3 dimensions: With side mounted auxiliary contact unit (UT-AX11) ... \*2 shows dimension for one unit, and \*3 shows dimensions with two units (both sides).

- SD-2xT65
- SD-2xT80

Reversing

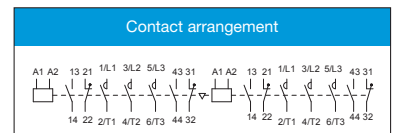
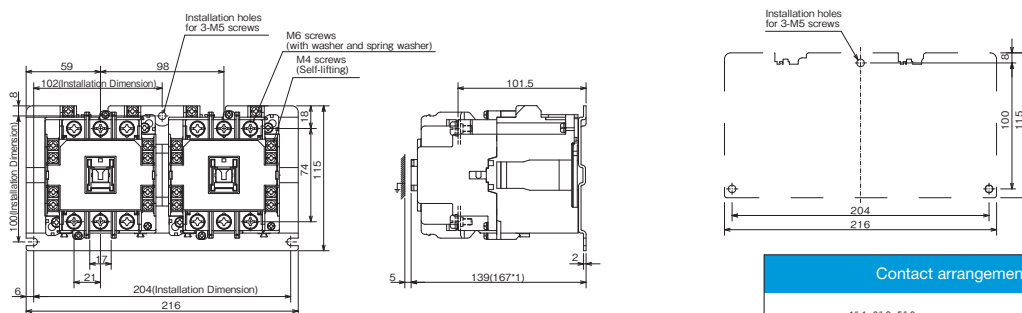

\*1 dimensions: With head mounted auxiliary contact unit (UT-AX2, UT-AX4)





## Contactor Relays (AC operated)

### SR-T5(BC)

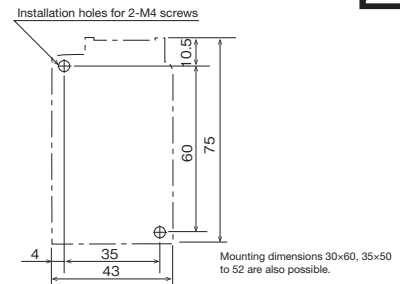
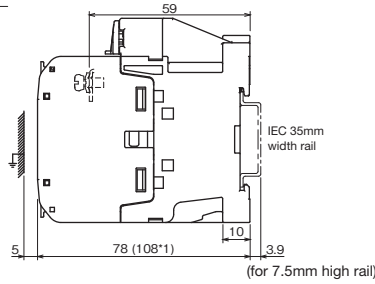
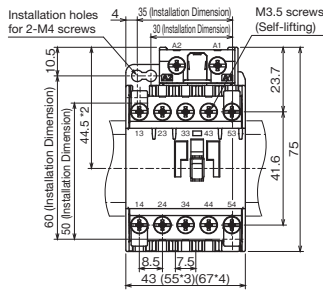

\*1 dimensions: With head mounted auxiliary contact unit (UT-AX2(BC), UT-AX4(BC))  
 \*2 dimensions: Dimensions from center of IEC 35mm width rail  
 \*3, \*4 dimensions: With side mounted auxiliary contact unit (UT-AX11(BC)) ... \*3 shows dimension for one unit, and \*4 shows dimensions with two units (both sides).

### SR-T9(BC)

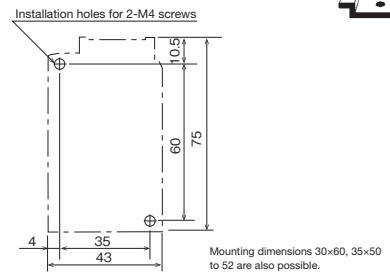
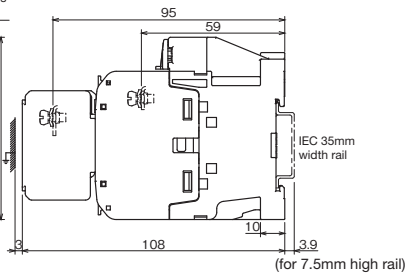
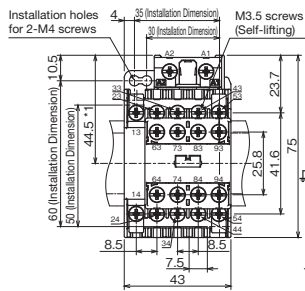

\*1 dimensions: Dimensions from center of IEC 35mm width rail

## Contactor Relays (DC operated)

### SRD-T5(BC)

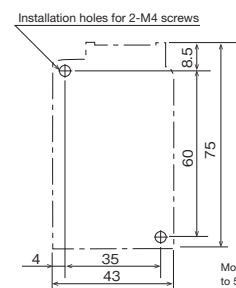
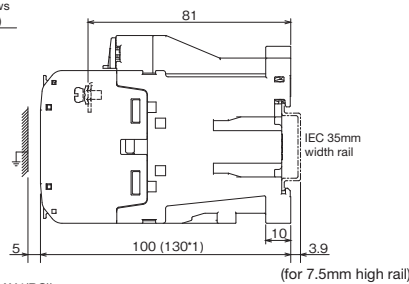
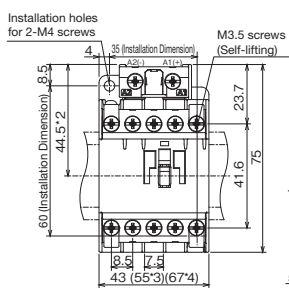

\*1 dimensions: With head mounted auxiliary contact unit (UT-AX2(BC), UT-AX4(BC))  
 \*2 dimensions: Dimensions from center of IEC 35mm width rail  
 \*3, \*4 dimensions: With side mounted auxiliary contact unit (UT-AX11(BC)) ... \*3 shows dimension for one unit, and \*4 shows dimensions with two units (both sides).

### SRD-T9(BC)

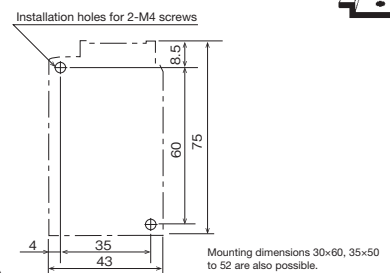
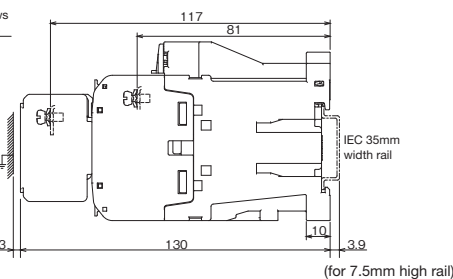
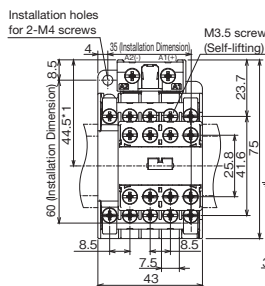

\*1 dimensions: Dimensions from center of IEC 35mm width rail

## Outline Drawing, Contact Arrangement

### Thermal Overload Relays

#### ● TH-T18(BC)(KP)

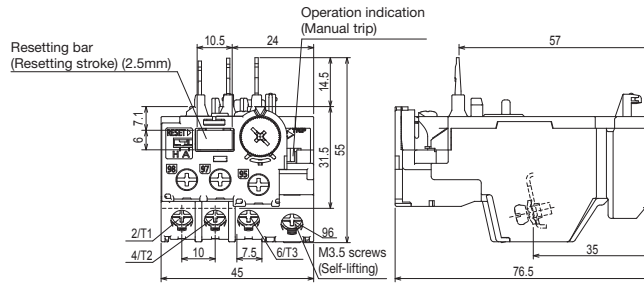

Model name	Contact arrangement
TH-T18	
TH-T18KP	

For combination with the following magnetic contactors  
 TH-T18: S-T10, T12, T20 SD-T12, T20  
 Independent use is possible by combining with the independent mounting unit UT-HZ18

#### ● TH-T18SR

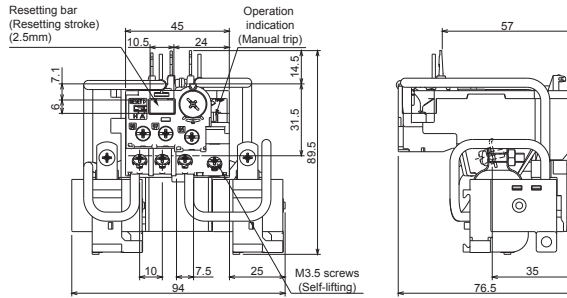

Model name	Contact arrangement
TH-T18SR	

For combination with the following magnetic contactors  
 TH-T18SR: S-T10, T12, T20 SD-T12, T20  
 Independent use is possible by combining with the independent mounting unit UT-HZ18

#### ● TH-T25(BC)(KP)

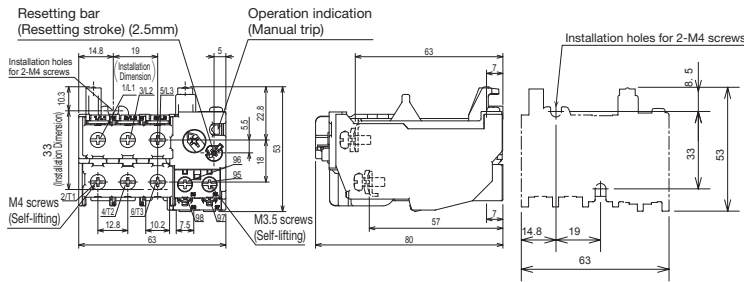

Model name	Contact arrangement
TH-T25	
TH-T25KP	

Use the following connection conductor (option) when using in combination with the magnetic contactor  
 Combination with S-T35/T50(BC), SD-T35/T50(BC), SL(D)-T35/T50(BC); UT-TH50  
 DIN rail independent mounting possible when used in combination with independent mounting unit UN-RM20

#### ● TH-T25(BC)(KP)SR

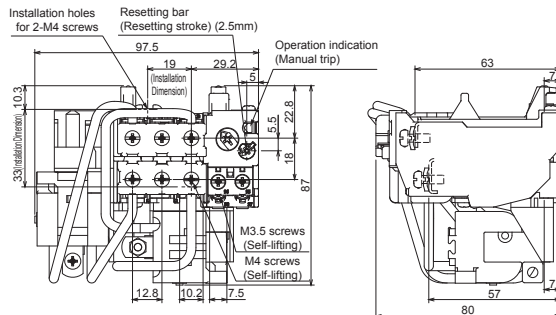

Model name	Contact arrangement
TH-T25 (BC)SR	
TH-T25 (BC)KPSR	

Use the following connection conductor (option) when using in combination with the magnetic contactor  
 Combination with S-T35/T50(BC), SD-T35/T50(BC), SL(D)-T35/T50(BC); UT-TH50  
 \* The reversing Magnetic Contactor with wiring streamlining terminal cannot be combined with TH-T25BC(KP)SR.

● TH-T50(BC)(KP)

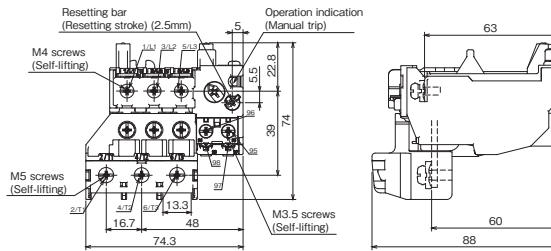

Model name	Contact arrangement					
TH-T50(FS) TH-T50BC(FS)	1/L1	3/L2	5/L3	97	95	
	2/T1	4/T2	6/T3	98	96	
TH-T50(FS)KP TH-T50BC(FS)KP	1/L1	3/L2	5/L3	97	95	
	2/T1	4/T2	6/T3	98	96	

Use as an independent unit is not possible.  
 When combining with the Magnetic Contactor, use the following connection conductor kit (optional).  
 Combination with S-T35/T50(BC), SD-T35/T50(BC); UT-TH50

● TH-T50(BC)(KP)SR

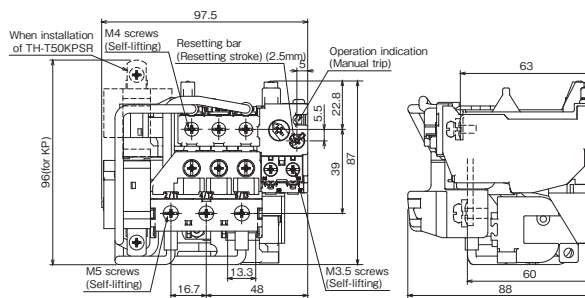

Model name	Contact arrangement					
TH-T50SR	1/L1	3/L2	5/L3	97	95	
	2/T1	4/T2	6/T3	98	96	
TH-T50KPSR	1/L1	3/L2	5/L3	97	95	
	2/T1	4/T2	6/T3	98	96	

Use as an independent unit is not possible.  
 When combining with the Magnetic Contactor, use the following connection conductor kit (optional).  
 Combination with S-T35/T50(BC), SD-T35/T50(BC); UT-TH50

● TH-T65(KP)

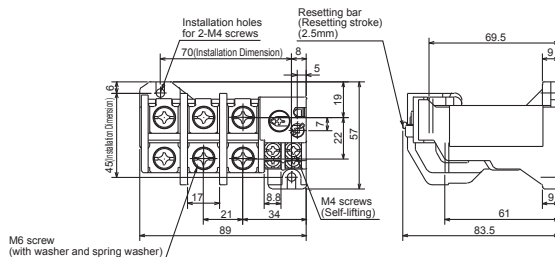

When combining with the Magnetic Contactor, use the following connection conductor kit (optional).  
 Combination with S(D)-N50/N65, SL(D)-N50/N65: BH559N350  
 Combination with S-N80/N95, SL(D)-N80/N95: BH569N350  
 Combination with SD-N80/N95: BH569N352  
 TH-N60 and TH-N60KP can be used either for the Magnetic Starter (MSO) or independent mounting.  
 Note: With TH-N60CX, the width is 92 and the depth is 87.

Model name	Contact arrangement					
TH-T65(FS)	1/L1	3/L2	5/L3	97	95	
	2/T1	4/T2	6/T3	98	96	
TH-T65(FS)KP	1/L1	3/L2	5/L3	97	95	
	2/T1	4/T2	6/T3	98	96	

● TH-T65(KP)SR

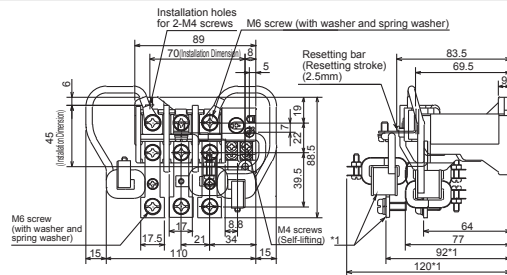

\*1 applies for TH-N60(TA)KPSR.  
 When combining with the Magnetic Contactor, use the following connection conductor kit (optional).  
 Combination with S(D)-N50/N65, SL(D)-N50/N65: BH559N350  
 Combination with S-N80/N95, SL(D)-N80/N95: BH569N350  
 Combination with SD-N80/N95: BH569N352  
 TH-N60TA(KP)SR cannot be used with independent mounting.

Model name	Contact arrangement					
TH-T65SR	1/L1	3/L2	5/L3	97	95	
	2/T1	4/T2	6/T3	98	96	
TH-T65KPSR	1/L1	3/L2	5/L3	97	95	
	2/T1	4/T2	6/T3	98	96	

MS-T Series Introduction

Selection and Application

Application to Thermal Overload Relays

Product Introduction

Overseas Standard

Type Codes

Order Procedure

Outline Drawing

Warranty and Safety

## Outline Drawing, Contact Arrangement

### Thermal Overload Relays

#### ● TH-T100(KP)

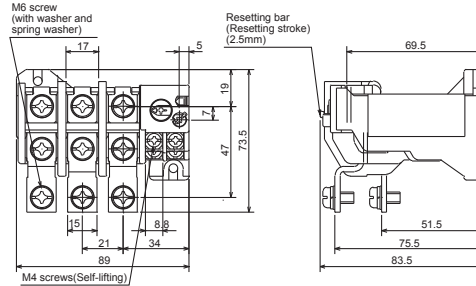

Use with independent mounting is not possible.  
 When combining with the Magnetic Contactor, use the following connection conductor kit (optional).  
 Use the connection conductor kit (optional, type: BH569N350)  
 Combination with S-N80/N95, SL(D)-N80/N95: BH569N350  
 Combination with SD-N80/N95: BH569N352

Model name	Contact arrangement					
TH-T100(FS)	1/L1	3/L2	5/L3	97	95	
	2/T1	4/T2	6/T3	98	96	
TH-T100(FS)KP	1/L1	3/L2	5/L3	97	95	
	2/T1	4/T2	6/T3	98	96	

#### ● TH-T100(KP)SR

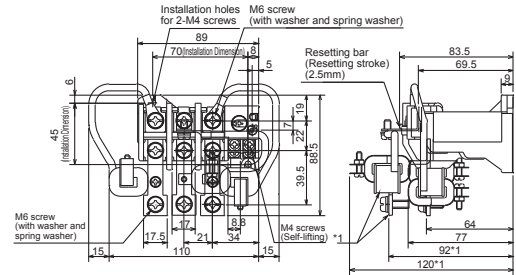

\*1 applies for TH-N60(TA)KPSR.  
 When combining with the Magnetic Contactor, use the following connection conductor kit (optional).  
 Combination with S(D)-N50/N65, SL(D)-N50/N65: BH559N350  
 Combination with S-N80/N95, SL(D)-N80/N95: BH569N350  
 Combination with SD-N80/N95: BH569N352  
 TH-N60TA(KP)SR cannot be used with independent mounting.

Model name	Contact arrangement					
TH-T100SR	1/L1	3/L2	5/L3	97	95	
	2/T1	4/T2	6/T3	98	96	
TH-T100KPSR	1/L1	3/L2	5/L3	97	95	
	2/T1	4/T2	6/T3	98	96	



## Optional Units

### ● UT-AX2(BC)

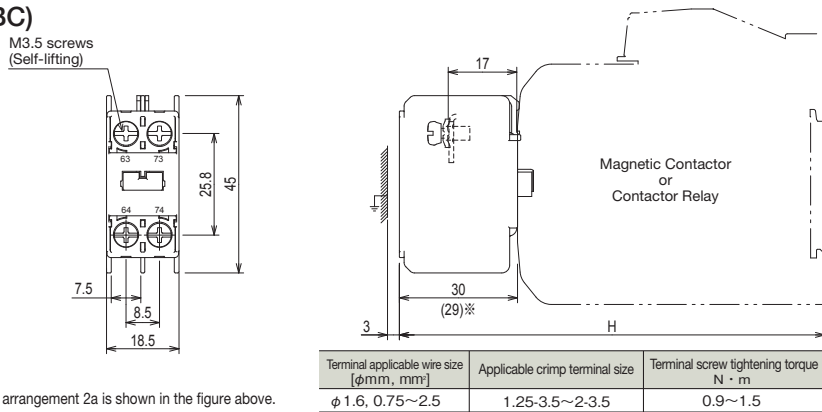

Note: The contact arrangement 2a is shown in the figure above.

Terminal applicable wire size [φmm, mm]	Applicable crimp terminal size	Terminal screw tightening torque N · m
φ 1.6, 0.75~2.5	1.25-3.5~2-3.5	0.9~1.5

Application		
	Applicable model	Dimension H
Magnetic Contactor	S-T10, T12, T20	108
	S-T21, T25, T32	111
	S-T35, T50 ※	120
	SD-T12/20	130
	SD-T21, T32	138
Contact Relay	SD-T35, T50 ※	152
	SR-T5	108
	SRD-T5	130

Contact arrangement					
2a		1a1b		2b	
63	73	63	71	61	71
64	74	64	72	62	72

### ● UT-AX4(BC)

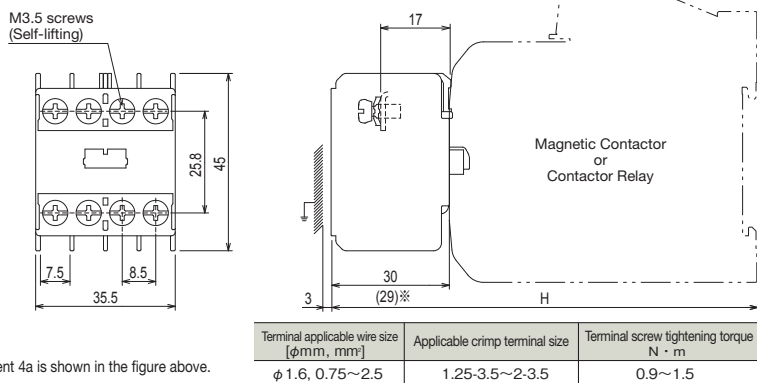

Note: The contact arrangement 4a is shown in the figure above.

Terminal applicable wire size [φmm, mm]	Applicable crimp terminal size	Terminal screw tightening torque N · m
φ 1.6, 0.75~2.5	1.25-3.5~2-3.5	0.9~1.5

Application		
	Applicable model	Dimension H
Magnetic Contactor	S-T10, T12, T20	108
	S-T21, T25, T32	111
	S-T35, T50 ※	120
	SD-T12/20	130
	SD-T21, T32	138
Contact Relay	SD-T35, T50 ※	152
	SR-T5	108
	SRD-T5	130

Contact arrangement											
4a		3a1b		2a2b							
63	73	83	93	63	71	83	93	63	71	81	93
64	74	84	94	64	72	84	94	64	72	82	94

### ● UT-AX11(BC)

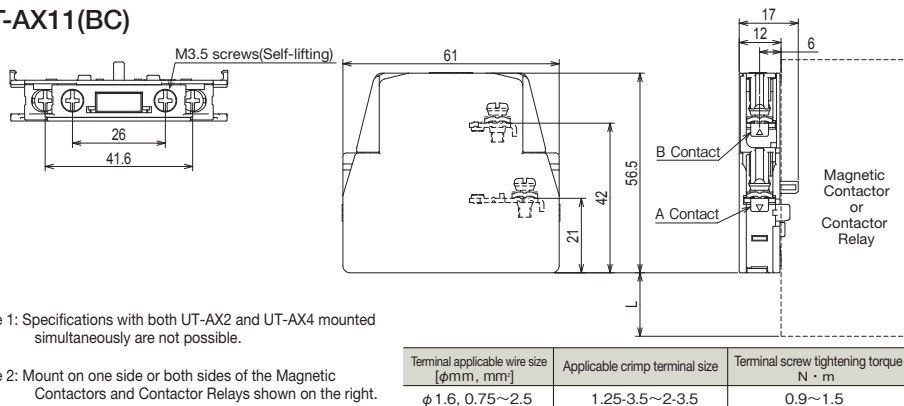

Note 1: Specifications with both UT-AX2 and UT-AX4 mounted simultaneously are not possible.

Note 2: Mount on one side or both sides of the Magnetic Contactors and Contactor Relays shown on the right.

Terminal applicable wire size [φmm, mm]	Applicable crimp terminal size	Terminal screw tightening torque N · m
φ 1.6, 0.75~2.5	1.25-3.5~2-3.5	0.9~1.5

Application		
	Applicable model	Dimension L
Magnetic Contactor	S-T10, T12, T20	18
	S-T21, T25	19
	S-T32	22.5
	S-T35, T50	18.8
	SD-T12/20	40
Contact Relay	SD-T21	46
	SD-T32	44
	SD-T35, T50	50.8
	SR-T5	18
	SRD-T5	40

Contact arrangement			
Example of mounting on left side of unit		Example of mounting on right side of unit	
63	71	93	81
64	72	94	82

### ● UT-ML11

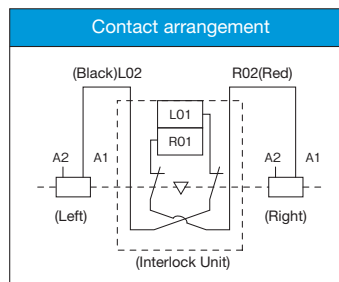
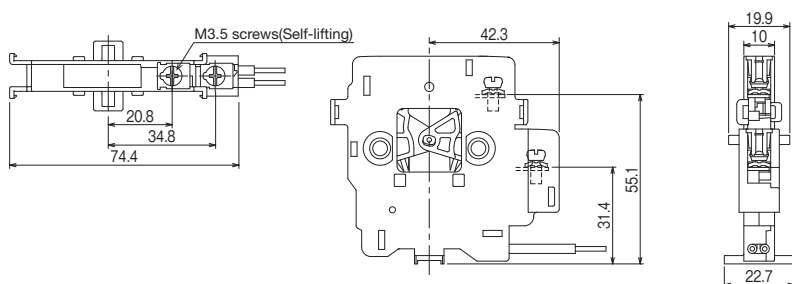

MS-T Series Introduction

Selection and Application

Application to Thermal Overhaul Relays

Product Introduction

Overseas Standard

Type Codes

Order Procedure

Outline Drawing

Warranty and Safety





## [Notes for adopting the product]

Before purchasing and using our products, please confirm the following product warranty.



### Period and scope of warranty

#### ●Warranty period

- (1) The warranty period for our products shall be one year after purchase or delivery to the designated location. However the maximum warranty period shall be 18 months after production, in consideration that the maximum length of distribution period is to be 6 months after shipping.
- (2) This warranty period may not apply in the case where the use environment, use conditions, or the number of open/close operation times specifically impact the lives of products.

#### ●Scope of warranty

- (1) When any failure occurs during the above warranty period which is clearly our responsibility, we will replace or repair the failed portion of the product free of charge at the location of purchase or delivery.  
Note that the "failure" mentioned here shall not include such items as scratches and discoloration which do not affect performance.
- (2) In the following cases, even during the warranty period, charged repair services shall be applied.
  - ① Failures caused by inappropriate conditions, environment, handling, and uses other than those specified in catalogs, instruction manuals or specifications.
  - ② Failures caused by inappropriate installation.
  - ③ Failures caused by the design of customer's equipment or software.
  - ④ Failures caused by the customer tampering with our products such as reworks without our authorization.
  - ⑤ Failures caused by the customer failing to correctly maintain or replace components such as spare parts, as specified by documents such as instruction manuals.
  - ⑥ Failures caused by uses of the product other than ordinarily intended.
  - ⑦ Failures caused by force majeure such as fire and abnormal voltage accidents, and natural disasters such as earthquake, wind and flood.
  - ⑧ Failures caused by reasons that were unforeseeable by the level of technology at the time of shipment.
- (3) The warranty that is mentioned here shall mean warranty of the unit of delivery, and any losses induced by the failures of delivered products shall be excluded from our warranty.

#### ●Failure diagnosis

In principle, primary failure diagnosis shall be conducted by the customer. However this job, if requested by the customer, can be performed by us or our service company with charge. In this case, a service fee shall be charged to the customer in accordance with our price list.

### Recommendation for renewal due to life

Our Magnetic Starters and Magnetic Contactors with contacts and mechanical parts have certain wear life in line with the number of switching operations, while our coil wires and electronic parts have aging degradation life influenced by the use environment and use conditions.

Regarding the use of our Magnetic Starters and Magnetic Contactors, we recommend customers to renew the products every 10 years as a rule, provided that the products are used in

line with the number of open/close operations specified by this catalog or the instruction manual.

We also recommend to renew devices other than the Magnetic Starters and Magnetic Contactors described in this catalog every 10 years as a rule.

### Exemption from warranty related to opportunity or secondary losses.

Regardless of in or out of warranty period, loss of opportunity and lost earnings at the customer side caused by the failures of our products, any damages caused by special situation regardless of our foreseeability, secondary losses, accident compensation, damages on anything other than our products, compensation to jobs including replacement work, readjustment of field machinery equipment, startup test run, etc. performed by customers, and damages caused by any reasons for which we are not held responsible, shall be outside the scope of our compensation.

### Exemption from warranty related to opportunity or secondary losses.

- (1) The contents of products shown in this catalog are for your selection of models. When you actually use the product, read the "Instruction Manual" carefully beforehand and use correctly.  
Please note that the external view or specifications that should not affect the model selection can change without preannouncement.
- (2) When using a product listed in this catalog, you are required to accept that your use should not lead to any serious accident if by any chance the product develops any failures or errors, and, in the event any failure or error occurs, backup or fail-safe functions are in place outside the device by the system.
- (3) The products described in this catalog are designed and manufactured as general products to be used for general industrial fields. For this reason, the products described in this catalog should not be used for the applications requiring special quality assurance systems, such as serious public uses as atomic power plants and other power plants owned by power companies, railway applications and government and public office applications.  
Note, however, that the products shall be applicable to such uses if the use is limited and the customer agrees not to require specially high quality.  
Furthermore, when the customer is investigating application for the uses where serious impact is foreseen to the human body and assets and therefore high reliability for security and control system is required, such as aviation, medical services, railways, combustion and fuel equipment, manned transportation equipment, entertainment facilities and security machines, please contact our representatives and discuss any necessary agreement or specifications.

### Supply period of spare goods after production stop

- (1) For the discontinuation of production, we will announce in such media as "Sales and Service" paper created by us.

## [Notes for security related issues]

- Before performing the installation, wiring works, operation and maintenance/check for the products described in this catalog, make sure to read the "Instruction Manual" or "Notes for Use" attached to the product for correct usage.
- With the MS-T Series, the parts such as the contact and coil cannot be replaced so do not modify or disassemble the product. Failure to observe this can lead to faults.
- In spite of our continued efforts to enhance the quality and reliability of our product, the product can fail. The products described in this catalog can bring about serious results, such as malfunctions of machinery, short circuit at power supply, and catching fire), by the malfunction caused by vibration, physical shock and improper wiring. Pay special attention to avoid any secondary accidents such as injuries and fire, as the result of failures or malfunctions.
- When you find any questions or you need more details after reading this catalog, please contact your dealer or our company.

[For using the products described in this catalog, please observe the following items. ]

### Danger

- Make sure to disconnect the power before you perform installation, removal, wiring works, or maintenance/checking. There is a risk of receiving an electric shock or occurrence of a malfunction.
- When the product is energized, avoid touching or coming near the product, especially the terminals having electricity. There is a risk of receiving an electric shock or burn injury.

### Notes

- Use the product in the use environment described in this catalog and Instruction Manual. Do not install the product in any abnormal environment with high temperature, high humidity, dust, corrosive gas or excessive vibration/shock. There is a risk of catching fire, malfunctions, electric shock or failure.
- Avoid applying shocks by dropping or falling the product during transportation and unpacking. This will lead to breakage or failure of products.
- Do not use the product when it has received damage during transportation, installation or wiring. This can cause fire or malfunctions.
- Make sure that only technicians qualified for electric work or wiring should perform installation, wiring works and maintenance/checking of the product.
- Make sure that no foreign objects such as dust, iron powder and wire chips enter the product during installation and wiring works. There is a risk of contact failures and malfunctions leading to damage or fire at the load.
- When you use mounting screws of the wrong size or use a small number of screws than specified, or when the mounting to the rail of IEC 35mm width is defective, there is a risk that the product may fall.
- When you apply wiring works, be sure to use the wire size that suits the applied voltage, flow current and inrush current, and to fasten wires with the correct torque as specified in this catalog or the instruction manual. Defective wiring can cause fires, accidents and failures.
- To terminal screws and mounting screws, apply the torque as we specify for tightening, and regularly apply retorquing. When the tightening torque is too large, the work can damage terminal screws or mounting screws. When the terminal screws or mounting screws slacken or are broken, they can cause overheat or fire, or the body can fall off to create serious accidents.
- Confirm the rated values and specifications, and make sure to use a product that meets the requirements. When you use a product exceeding the rated/specified values, it may cause insulation breakdown leading to earth fault or short circuit accidents, or create the cause of fire by overheat or breakdown due to inability to shutdown.
- When a product described in this catalog is to be used in a facility where a failure can lead to injury to the human body or serious damage to earnings, make sure to install some safety mechanism.
- Apply regular checks to the product and use safety measures on the sequence to the critical circuits. The contacts of Contactors and Magnetic Starters can develop defective conduction, welding or burnout.
- Contactors and Magnetic Starters can create welding of contacts disabling the opening, due to such causes as switching operation for excessive current, abnormal wearing of contacts, chattering at operational instruction contacts, aging degradation and product life. Also the contacts may fail to open due to unexpected mechanical constraints other than contact adhesion. Since the disability of contact to open can cause the machine to go out of control, secure safety by assuming the mechanical constraints or contact welding leading to inability of open/close operations. There remains a risk of fire even when an overload protective device (Thermal Overload Relays) is provided.
- The example connection described in this catalog only shows a typical one to run a system. For the protection of each device and safety measures, the customer is requested to consider the connection for each system.
- Do not apply reworks to the product or disassemble the product. These may cause failures.
- When you dispose of the products, treat them as industrial waste products.

## [Related Products]

Low-voltage switch | Mitsubishi Manual Motor Starter MMP-T Series

Now the Magnetic Contactor MS-T Series (DC operated type) can be combined with the Manual Motor Starter (MMP-T Series) that saves space while protecting the motor circuit (overload, open-phase, short-circuit)!



MMP-T32

### What is the Manual Motor Starter?

The manual motor starter integrates the wiring breaker with the thermal relay functions and can be used on the motor circuit. A single module provides overload, open-phase and short-circuit protection.

### Space-saving design helps downsize the panel

Examples of space saving

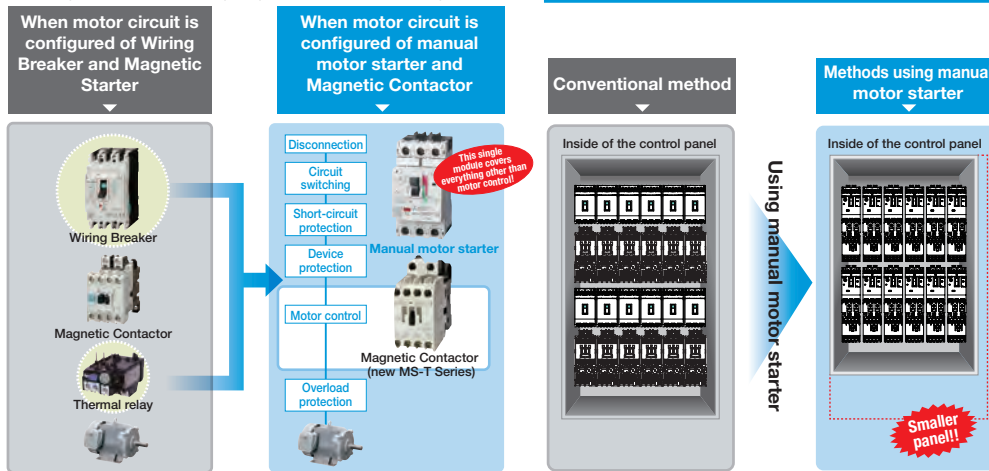

### Wire-saving

Wiring work can be reduced by using the connection conductor unit (option) when wiring the manual motor starter and contactor. A conductor unit for connection to the high-sensitivity contactor (SD-Q) is also available. (Type: UT-MQ12)

### Examples of wire-saving applications

#### Examples of wiring with wire

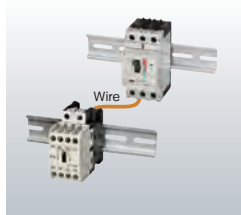

#### Example of wiring with connection conductor unit

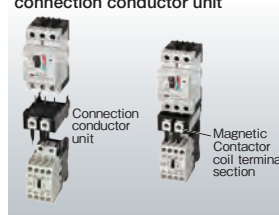

Example of using UT-MQ12

### Ease-of-use

A variety of optional units are available to meet your various needs.

#### Option configuration drawing

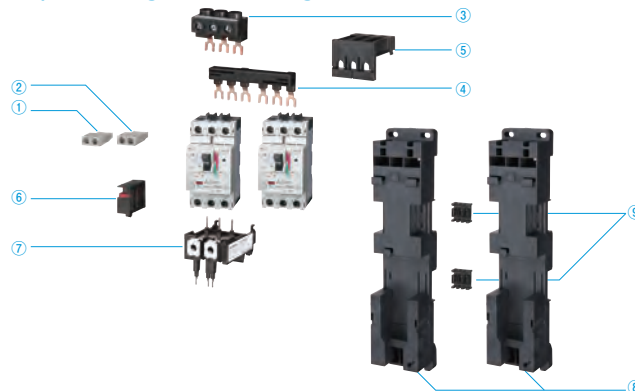

Model name	No.	Type	Explanation
Auxiliary contact (internal)	①	UT-MAX UT-MAXLL (for micro-loads)	With this unit, the contact operates in sequence with the unit's ON/OFF state.
Warning contact (internal)	②	UT-MAL UT-MALLL (for micro-loads)	With this unit, the contact operates in sequence with the unit's tripping action (regardless of cause).
Power supply block	③	UT-EP3 UT-2B4	This unit connects the power supply circuit's wires.
Bus bar	④	UT-3B4 UT-2B5 UT-3B5	This unit feeds power to two to three units.
Power supply side terminal cover	⑤	UT-CV3	Power supply side terminal cover for UL60947-4-1A, Type E/F.
Short-circuit display unit	⑥	UT-TU	This unit activates and displays in red only when the main unit trips with a short circuit. Required for application with UL60947-4-1A, Type E/F.
Connection conductor unit	⑦	UT-MT20 UT-MT32 UT-MQ12 UT-MT20D UT-MT32D	This unit electrically and mechanically connects and joins the MMP-T32 and Magnetic Contactor.
Mounting base unit	⑧	UT-BT20 UT-BT32 UT-BT32D	The combination starter is mounted on this plate when using the MMP-T32 and Magnetic Contactor combination. Both rail mounting and screw mounting are supported.
Reversible connection unit	⑨	UT-RT10 UT-RT20 UT-RT32	This block mechanically connects two mounting base units.

## PLC

## MELSEC iQ-R Series



Revolutionary, next generation controllers building a new era in automation

- ◎High-speed, high-accuracy multiple CPU control system based on the iQ Platform
- ◎New high-speed system bus and inter-module sync realizes improved productivity and reduced TCO\*
- ◎Reducing development costs through intuitive engineering (GX Works3)
- ◎Robust security features (such as security key authentication, IP filter)

## Product Specifications

Program capacity	40K steps to 1200K steps
LD instruction speed	0.98 ns
Available modules	I/O, analog, high-speed counter, positioning, simple motion, network module
Control system architecture	Rack-mounted modular based system
Supported networks	Ethernet, CC-Link IE Control Network, CC-Link IE Field Network, CC-Link, RS-232, RS-422/485

\*Total Cost of Ownership

## HMI

## Graphic Operation Terminal GOT2000 Series GT27 Model



To the top of HMIs with further user-friendly, satisfactory standard features.

- ◎Comfortable screen operation even if high-load processing (e.g. logging, device data transfer) is running. (Monitoring performance is twice faster than GT16)
- ◎Actual usable space without using a SD card is expanded to 128MB for more flexible screen design.
- ◎Multi-touch features, two-point press, and scroll operations for more user-friendliness.
- ◎Outline font and PNG images for clear, beautiful screen display.

## Product Specifications

Screen size	15", 12.1", 10.4", 8.4", 5.7"
Resolution	XGA, SVGA, VGA
Intensity adjustment	32-step adjustment
Touch panel type	Analog resistive film
Built-in interface	RS-232, RS-422/485, Ethernet, USB, SD card
Applicable software	GT Works3
Input power supply voltage	100 to 240VAC (+10%, -15%), 24VDC (+25%, -20%)

## AC Servo

## Mitsubishi General-Purpose AC Servo MELSERVO-J4 Series



Industry-leading level of high performance servo

- ◎Industry-leading level of basic performance: Speed frequency response (2.5kHz), 4,000,000 (4,194,304p/rev) encoder
- ◎Advanced one-touch tuning function achieves the one-touch adjustment of advanced vibration suppression control II, etc.
- ◎Equipped with large capacity drive recorder and machine diagnosis function for easy maintenance.
- ◎2-axis and 3-axis servo amplifiers are available for energy-conservative, space-saving, and low-cost machines.

## Product Specifications

Power supply specifications	1-phase/3-phase 200V AC, 1-phase 100V AC, 3-phase 400V AC, 48V DC/24V DC
Command interface	SSCNET III/H, SSCNET III (compatible in J3 compatibility mode), CC-Link IE Field Network interface, pulse train, analog
Control mode	Position/Speed/Torque/Positioning function/Fully closed loop
Speed frequency response	2.5kHz
Tuning function	Advanced one-touch tuning, advanced vibration suppression control II, robust filter, etc.
Functional safety	Conforms to functions of IEC/EN 61800-5-2, STO: Category 3 PL d, SIL 3 Conforms to Category 4 PL e, SIL 3 by a combination with MR-D30 functional safety unit
Compatible servo motor	Rotary servo motor (rated output: 0.01 to 55kW), linear servo motor (continuous thrust 50 to 3000N), direct drive motor (rated torque: 2 to 240N·m)

## [Related Products]

Inverter

FR-A800 Series



High-functionality, high-performance inverter

- ◎Realize even higher responsiveness during real sensor-less vector control or vector control, and achieve faster operating frequencies.
- ◎The latest automatic tuning function supports various induction motors and also sensor-less PM motors.
- ◎The standard model is compatible with EU Safety Standards STO (PLd, SIL2). Add options to support higher level safety standards.
- ◎Control and monitor inverters via CC-Link/CC-Link IE Field Network (option interface).

Product Specifications

Inverter capacity	200V class: 0.4kW to 90kW, 400V class: 0.4kW to 500kW
Control method	High-carrier frequency PWM control (Select from V/F, advanced magnetic flux vector, real sensorless vector or PM sensorless vector control), vector control (when using options)
Output frequency range	0.2 to 590Hz (upper limit is 400Hz when using advanced magnetic flux vector control, real sensorless vector control, vector control or PM sensorless vector control)
Regenerative braking torque (Maximum allowable duty)	200V class: 0.4K to 1.5K (150% at 3%ED) 2.2K/3.7K (100% at 3%ED) 5.5K/7.5K (100% at 2%ED) 11K to 55K (20% continuous) 75K or more (10% continuous), 400V class: 0.4K to 7.5K (100% at 2%ED) 11K to 55K (20% continuous) 75K or more (10% continuous)
Starting torque	200% 0.3Hz (3.7K or less), 150% 0.3Hz (5.5K or more) (when using real sensorless vector, vector control)

Robot

MELFA F Series



High speed, high precision and high reliability industrial robot

- ◎Compact body and slim arm design, allowing operating area to be expanded and load capacity increased.
- ◎The fastest in its class using high performance motors and unique driver control technology.
- ◎Improved flexibility for robot layout design considerations.
- ◎Optimal motor control tuning set automatically based on operating position, posture, and load conditions.

Product Specifications

Degrees of freedom	Vertical:6 Horizontal:4
Installation	Vertical:Floor-mount, ceiling mount, wall mount (Range of motion for J1 is limited) Horizontal:Floor-mount
Maximum load capacity	Vertical:2-70kg Horizontal:3-20kg
Maximum reach radius	Vertical:504-2,050mm Horizontal:350-1,000mm

Low Voltage Circuit Breakers

Mitsubishi WS-V Series Molded Case Circuit Breakers, Earth Leakage Circuit Breakers



Technologies based on long year experience realize more improved performance.

- ◎The new electronic circuit breakers can display various measurement items.
- ◎Improvement of breaking performance with new breaking technology "Expanded ISTAC".
- ◎Compliance with global standard for panel and machine export.
- ◎Commoditization of internal accessories for shorter delivery time and stock reduction.

Product Specifications.

Ampere Frame	32-250A Frame
Applicable standard	Applicable to IEC, GB, UL, CSA, JIS and etc.
Expansion of UL listed product line-up	New line-up of 480VAC type with high breaking performance for SCCR requirement
Commoditization of internal accessories	Reduction of internal accessory types from 3 to 1
Commoditization for AC and DC circuit use	Common use of 32/63A frame in both AC and DC circuit
Compact size for easy to use	Thermal adjustable and electronic circuit breakers are same size as 250AF fixed type
Measuring Display Unit (MDU) breakers	MDU breakers measure, display and transmit energy data to realize energy management.









# Magnetic Contactors and Magnetic Starters



**for a greener tomorrow**

Eco Changes is the Mitsubishi Electric Group's environmental statement, and expresses the Group's stance on environmental management. Through a wide range of businesses, we are helping contribute to the realization of a sustainable society.



Mitsubishi Electric Corporation Nagoya Works is a factory certified for ISO14001 (standards for environmental management systems) and ISO9001 (standards for quality assurance management systems)



## Safety Warning

To ensure proper use of the products listed in this catalog, please be sure to read the instruction manual prior to use.



## MITSUBISHI ELECTRIC CORPORATION

HEAD OFFICE: TOKYO BLDG., 2-7-3, MARUNOUCHI, CHIYODA-KU, TOKYO 100-8310, JAPAN  
[www.MitsubishiElectric.com](http://www.MitsubishiElectric.com)